



OPERATOR'S MANUAL
AND
SET-UP INSTRUCTIONS
FOR THE

WDL-2100
REAR-FOLD TRANSPORT CART
& HARROW SECTIONS

Version: 13661 (02-18)
Serial Number 21285 - higher

TO THE OWNER AND OPERATORS

Before assembling or operating this unit, READ THIS MANUAL THOROUGHLY. To obtain the best performance of the unit, familiarize yourself with each component and adjustment. Store this manual where it can be readily available for future reference. If the harrow or any part of the unit should be sold, be sure that the new owner receives a copy of this manual for their reference.

1330 Dallas Street · PO Box 100 · Sauk City WI 53583
Phone (608) 643-3321 · Toll Free (800) 627-8569 · Fax (608) 643-3976
www.mcfarlaneag.com

TABLE OF CONTENTS

INTRODUCTION	3
LIMITED WARRANTY	3
SAFETY	4
CONTACT INFORMATION.....	5
LIGHTING AND MARKING.....	6
SAFETY SIGN CARE	6 - 7
TIRE SAFETY.....	7 - 8
BEFORE OPERATION.....	7 - 8
DURING OPERATION	8 - 9
FOLLOWING OPERATION	9
HIGHWAY AND TRANSPORT OPERATIONS	9 - 10
PERFORMING MAINTENANCE	10 - 11
MAINTENANCE AND SERVICE SCHEDULE	11
OPERATING SUGGESTIONS.....	11
ASSEMBLY SUGGESTIONS.....	12
ASSEMBLY INSTRUCTIONS	13 - 39
DECAL APPLICATION AND FINAL ADJUSTMENTS	40- 41
TROUBLESHOOTING.....	42
BOLT TORQUE SPECIFICATIONS	APPENDIX A
PARTS DIAGRAMS AND LISTS	APPENDIX B
LAYOUT DIAGRAMS.....	APPENDIX C
WARRANTY REGISTRATION FORM.....	61
DEALER CONTACT INFORMATION.....	LAST PAGE

INTRODUCTION

Thank you for purchasing your new McFarlane transport cart and harrow sections. We know that you will get many years of dependable service from this modernly designed unit.

You may have had a particular application in mind when you purchased this unit. There are actually many uses for the McFarlane harrow including incorporation of herbicides and pesticides, leveling and smoothing tilled soil, and covering of broadcast seeds. Contact your dealer if you would like more information or have questions concerning these or other applications.

LIMITED WARRANTY

FULL ONE - YEAR WARRANTY OF WDL-2100 Models

If within one year from the date of purchase, this transport cart and/or its accompanying harrow sections fail due to defect in material or workmanship, McFarlane Mfg. Co., Inc. will repair it, free of charge.

Warranty service is available by simply contacting the nearest McFarlane dealership throughout the United States or Canada.

This warranty applies only while this product is used in the United States or Canada.

This warranty gives you specific legal rights, and you may have other rights which vary from state to state.

McFarlane Mfg. Co., Inc., Sauk City, Wisconsin 53583

SAFETY

TAKE NOTE! THIS SAFETY ALERT SYMBOL FOUND THROUGHOUT THIS MANUAL IS USED TO CALL ATTENTION TO INSTRUCTIONS INVOLVING YOUR PERSONAL SAFETY AND THE SAFETY OF OTHERS. FAILURE TO FOLLOW THESE INSTRUCTIONS CAN RESULT IN INJURY OR DEATH.



THIS SYMBOL MEANS

- **ATTENTION!**
- **BECOME ALERT!**
- **YOUR SAFETY IS INVOLVED!**

SIGNAL WORDS:

Note the use of the signal words DANGER, WARNING, and CAUTION with the safety messages. The appropriate signal word for each has been selected using the following guidelines:

DANGER: Indicates an imminently hazardous situation that, if not avoided, will result in death or serious injury.

WARNING: Indicates a potentially hazardous situation that, if not avoided, could result in death or serious injury.

CAUTION: Indicates a potentially hazardous situation that, if not avoided, may result in minor or moderate injury.

CONTACT INFORMATION

If you have questions not answered in this manual, require additional copies, or the manual is damaged, please contact your local dealer or:

McFarlane Mfg. Co., Inc.
1330 Dallas Street
P.O. Box 100
Sauk City, WI 53583

PHONE: (608) 643-3321
TOLL FREE: (800) 627-8569
FAX: (608) 643-3976



SAFETY FIRST!



Equipment Safety Guidelines

Safety of the operator is one of the main concerns in designing and developing a new piece of equipment. Designers and manufacturers build in as many safety features as possible. However, every year many accidents occur which could have been avoided by a few seconds of thought and a more careful approach to handling equipment. You, the operator, can avoid many accidents by observing the following precautions. To avoid personal injury, study the following precautions and insist that those working with you, or for you, follow them.

Replace any CAUTION, WARNING, DANGER, or instruction safety decal that is not readable or missing.

Do not attempt to operate this equipment under the influence of drugs or alcohol.

Review the safety instructions with all users annually.

This equipment is dangerous to children and persons unfamiliar with its operation. The operator should be a responsible adult familiar with farm machinery and trained in this equipment's operations. **Do not allow persons to operate or assemble this unit until they have read this manual and have developed a thorough understanding of the safety precautions and of how it works.**

To prevent injury, use a tractor equipped with a Roll Over Protective System (ROPS). Do not paint over, remove, or deface any safety signs or warning decals on your equipment. Observe all safety signs and practice the instructions on them.

Never exceed the limits of the transport cart or the harrows. If their ability to do a job, or to do so safely, is in question - **DO NOT TRY IT.**



Lighting and Marking

It is the responsibility of the customer to know the lighting and marking requirements of the local highway authorities and to install and maintain the equipment to provide compliance with the regulations. Add extra lights when transporting at night or during periods of limited visibility.

Lighting kits are available from your dealer.



Safety Sign Care

- Keep safety signs clean and legible at all times.
- Replace safety signs that are missing or have become illegible.
- Replacement parts that display a safety sign should display the same sign.
- Safety signs are available from your Distributor, Dealer Parts Department, or the factory.

How to Install Safety Signs:

- Be sure that the installation area is clean and dry.
- Decide on the exact position before you remove the backing paper.



Tire Safety

- Failure to follow proper procedures when mounting a tire on a wheel or rim can produce an explosion which may result in serious injury or death.
- Do not attempt to mount tires unless you have the proper equipment and experience to do the job.
- Inflating or servicing tires can be dangerous. Whenever possible, trained personnel should be called to service and/or mount tires.
- Always order and install tires and wheels with appropriate capacity to meet or exceed the weight of the unit. Be sure to inflate tires to tire manufacturer's specifications
- Tires that are provided by the manufacturer are designed for speeds LESS THAN 20mph. Do Not exceed or tire failure will occur.



Remember:

Your best assurance against accidents is a careful and responsible operator. If there is any portion of this manual or function you do not understand, contact your local authorized dealer or the manufacturer.



Before Operation:

- Carefully study and understand this manual.
- Do not wear loose fitting clothing which may catch in moving parts.
- Always wear protective clothing and substantial shoes.
- It is recommended that suitable protective hearing and (eye protection) sight protectors be worn.
- Keep wheel lug nuts or bolts tightened.
- Assure that the tires are inflated evenly.
- Give the unit a visual inspection for any loose bolts, worn parts, or cracked welds, and make necessary repairs. Follow the maintenance safety instructions included in this manual.
- Before using the hydraulics on the cart, be sure all fittings and connections are tight.
- Be sure that there are no tools lying on the unit.
- Make sure that the area is clear of children, animals, and other obstacles before using.
- Don't hurry the learning process or take the unit for granted. Ease into it and become familiar with your new equipment. Practice operation of your new unit. Completely familiarize yourself and other operators with its operation before using.

- Securely attach to towing unit. Use a high strength, appropriately sized hitch pin with a mechanical retainer and attach safety chain.
- Do not allow anyone to stand between the tongue or hitch and the towing vehicle when backing up to the equipment.



During Operation:

- **SAFETY CHAIN** - If equipment is going to be transported on a public highway, a safety chain should be obtained and installed. Always follow state and local regulations regarding a safety chain when towing farm equipment on a public highway. Be sure to check with local law enforcement agencies for your own particular regulations. Only a safety chain (not an elastic or nylon/plastic tow strap) should be used to retain the connection between the towing and towed machines in the event of separation of the primary attaching system.
- Install the safety chain by crossing the chains under the tongue and secure to the draw bar cage or hitch or bumper frame.
- Beware of bystanders, **particularly children!** Always look around to make sure that it is safe to start the engine of the towing vehicle or move the unit. This is particularly important with higher noise levels and quiet cabs, as you may not hear people shouting.
- **NO PASSENGERS ALLOWED** - Do not carry passengers anywhere on, or in, the tractor or equipment, except as required for operation.
- Keep hands and clothing clear of moving parts.
- Do not clean, lubricate, or adjust your equipment while it is moving.
- When altering operation, even periodically, set the tractor or towing vehicle brakes, shut off the engine, and **remove the ignition key.**
- Do not operate the hydraulic cylinders without the flow restrictors installed; the free falling harrow sections may cause serious injury.
- Pick the levellest possible route when transporting across fields. Avoid the edges of ditches or gullies and steep hillsides.
- Periodically clear the equipment of brush, twigs, or other materials to prevent buildup of dry combustible materials.
- Maneuver the tractor or towing vehicle at safe speeds.
- Avoid overhead wires or other obstacles. Contact with overhead lines could cause serious injury or death.
- Allow for unit length when making turns.
- Do not walk or work under raised wings unless securely positioned in wing rests.
- Keep all bystanders, pets, and livestock clear of the work area, particularly when raising or lowering harrow sections.
- Operate the towing vehicle from the operator's seat only.

- As a precaution, always recheck the hardware on equipment periodically. Correct all problems. Follow the maintenance safety procedures.



Following Operation:

- When disconnecting, stop the tractor or towing vehicle, set the brakes, lock the wings together with the tie-bar (see Transformation Instructions), relieve hydraulic fluid pressure, shut off the engine and **remove the ignition keys**. Make sure all jack and support stands are in place before removing hitch pins.
- Store the unit in an area away from human activity on a hard level surface.
- Do not park equipment where it will be exposed to livestock for long periods of time. Damage and livestock injury could result.
- Do not permit children to play on or around the stored unit.



Highway and Transport Operations:

- Make sure all transport lock provisions are in place and jack/parking stands are in their storage position before transporting the unit. Also, lock the wings together with the tie-bar (see Transformation Instructions).
- Adopt safe driving practices:
 - Keep the brake pedals latched together at all times. **NEVER USE INDEPENDENT BRAKING WITH MACHINE IN TOW AS LOSS OF CONTROL AND/OR UPSET OF UNIT MAY RESULT.**
 - Always drive at a safe speed relative to local conditions and ensure that your speed is low enough for an emergency stop to be safe and secure. Keep speed to a minimum.
 - Reduce speed prior to turns to avoid the risk of overturning.
 - Avoid sudden uphill turns on steep slopes.
 - Always keep the tractor or towing vehicle in gear to provide engine braking when going downhill. Do not coast.
 - Do not drink and drive!
- Comply with state and local laws governing highway safety and movement of farm machinery on public roads.
- Use approved accessory lighting flags and necessary warning devices to protect operators of other vehicles on the highway during daylight and nighttime transport. Various safety lights and devices are available from your dealer.
- The use of flashing amber lights is acceptable in most localities. However, some localities prohibit their use. Local laws should be checked for all highway lighting and marking requirements.
- When driving the tractor and equipment on the road or highway under 20 mph at night or driving during the day, use flashing amber warning lights and a slow moving vehicle (SMV) identification emblem.
- Remember, tires supplied by the manufacturer are designed to operate LESS THAN 20mph. Do Not exceed or tire failure will occur.

- Be a safe and courteous driver. Always yield to oncoming traffic in all situations, including narrow bridges, intersections, etc. Plan your route to avoid heavy traffic.
- Be observant of bridge loading ratings. Do not cross bridges rated lower than the gross weight at which you are operating.
- Watch for obstructions overhead and to the side while transporting.
- Always operate equipment in a position to provide maximum visibility at all times. Make allowances for increased length and weight of the equipment when making turns, stopping, etc.



Performing Maintenance:

- Good maintenance is your responsibility. Poor maintenance is an invitation to trouble.
- Before working on this machine, stop the tractor or towing vehicle, set the brakes, lower into field position, relieve the hydraulic fluid pressure, shut off the engine and **remove the ignition keys**.
- **Always** use safety support and block the wheels. When performing maintenance, never use a jack to support the machine. Assist the jack with blocks or other adequate support.
- Use extreme caution when making adjustments.
- When disconnecting hydraulic lines, shut off hydraulic supply and relieve all pressure.
- Never use hands to locate a hydraulic leak on attachments. Use a piece of cardboard or wood. Hydraulic fluid escaping under pressure can penetrate the skin.
- Openings in the skin and minor cuts are susceptible to infection from hydraulic fluid. **If injured by escaping hydraulic fluid, see a doctor at once. Gangrene can result. Without immediate medical treatment, serious infection and reactions can occur.**
- When installing, replacing, or repairing hydraulic system cylinders or parts, make sure that the entire system is charged and free of air before resuming operations. Failure to bleed the system of all air can result in improper machine operation, causing severe injury.
- After servicing, be sure all tools, parts, and service equipment are removed.
- Never replace hex bolts with less than grade five bolts unless otherwise specified.
- Where replacement parts are necessary for periodic maintenance and servicing, genuine factory replacement parts must be used to restore your equipment to original specifications. The manufacturer will not claim responsibility for damages as a result of the use of unapproved parts and/or accessories.
- If equipment has been altered in any way from original design, the manufacturer does not accept any liability for injury or warranty.

MAINTENANCE AND SERVICE SCHEDULE

- Prior to each use, check for loose bolts and replace lost or worn parts.
- Grease hinge pins before each use when necessary.
Note: Clean grease fittings and replace those that are broken or missing.
- Inspect and repack wheel bearings at the beginning of each year.
- Remove dirt and debris from the harrow sections before storage.
- Parts diagrams and listings for service and repair references may be found in appendix B.

OPERATING SUGGESTIONS

- To maximize the harrow's performance, it should be towed at speeds ranging from six to nine (6 - 9) mph. This keeps the field debris moving through the harrow sections and avoids clogging. The best results will be obtained after the paint has been scoured from the teeth.
- Choose the angle of attack of the harrow teeth based on field conditions. For more information see the section titled Angle of Attack.
- Getting the unit ready for field use includes the following steps:
 1. Move the cylinder lock bars to storage position. See Figure 5 on page 18.
 2. Disconnect the tie-bar on the left side and swing it forward and pin it to the stow bracket.
 3. Using the transport hydraulics rotate the transport wheels half way into field position, approximately 45°. Slowly back up until the wings are even with the center bar and the pull tube contacts the lock arm. As you back up, be sure the wings open evenly. Rotate the transport wheels fully into the field position.
 4. Rotate the toolbar down into field position only until the lock arm engages the pull tube and locks it into place.
 5. Drive forward and lower the unit into the field position.
- Getting the unit ready for transport includes the following steps:
 1. Rotate the harrows to the upright position.
 2. Using the transport hydraulics rotate the transport wheels half way into field position, approximately 45°. Slowly drive forward until the wings are straight back behind the unit.
 3. Rotate the transport wheels fully into the transport position.
 4. Rotate the cylinder lock bars back into the lock position. Same as number 1 above.
 5. Connect the tie-bar between the two wings.
- Field Operation - while turning on the headlands (field ends) slow down and rotate the toolbar up so the harrow sections begin to lift off the ground. Be sure not to rotate the toolbar too far, otherwise the pull tube lock will disengage and the wings will fold backwards resulting in severe damage. Once traveling straight forward again, lower the sections to the ground.

ASSEMBLY SUGGESTIONS

- You will find the machine is easier to assemble if the set-up instructions are followed in the order given in the manual.
- Before beginning, sort the various bolt bags, hardware bags and hydraulic bags according to what part of the unit that is being setup. Refer to the end of the parts listing in appendix B. Only open the bag or bags that are required as the setup instructions are followed.
- Whenever the terms “left” and “right” are used, it should be understood to mean when standing behind and facing the unit. This is also known as the “driver’s left” and the “driver’s right.”
- The term “field position” refers to the position the harrows are in when the unit is being used in the field - that is, with the wings out and the harrow sections down.
- The term “transport position” refers to the position the harrows would be in when the unit is being transported from place to place - that is, with the harrows up and the wings folded and secured with the tie-bar.
- When assembling, make sure the parts are securely held before proceeding to the next step.
- Bolt torque specifications are given in appendix A.

- The hydraulic cylinder and hose requirements are listed in the parts listing in appendix B. It is not recommended that other size cylinders or hoses be substituted. Hoses are marked with the part number near the ends. The last three digits indicate the hose length in inches. Fittings with a restrictor are marked with an ‘R’.
- A dual acting hydraulics supply is required.
- Tire requirements are also listed in the parts listing in appendix B.
- Layout diagrams for each unit may be found in appendix C. Mark the page with the diagram that refers to your unit, it will be referred to periodically throughout the manual.

STEP - BY - STEP ASSEMBLY INSTRUCTIONS

Attach the Axles to the Main Frame

1. Refer to Figures 1A and 1B. Figure 1A shows walking axle with 11L - 15 tires and Figure 1B shows dual axle with 14L - 16 tires. Bolt the main frame axle assemblies to the frame. Use 5/8" x 2" bolts and locking hex nuts. Note: when installing the 14L tires, it is recommended to pin the lift cylinder to the main frame first (see figure 3).
2. If the hub assemblies (WDL-2507) are not installed on the axle assemblies attach them using the 1/2-13 x 3 1/2 bolts and locking nuts. Need to show this, they are not assembled
3. Mount the wheels with either 11L - 15 or 14L - 16 tires on the main frame axle assemblies.

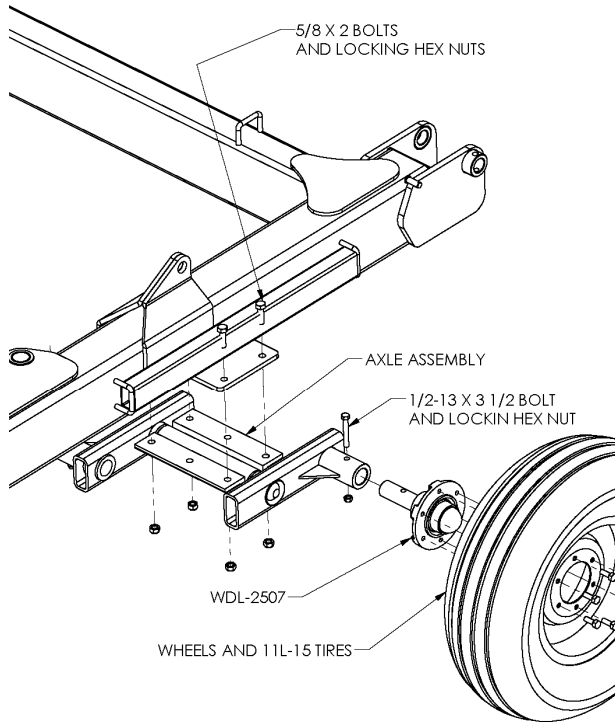

Figure 1A

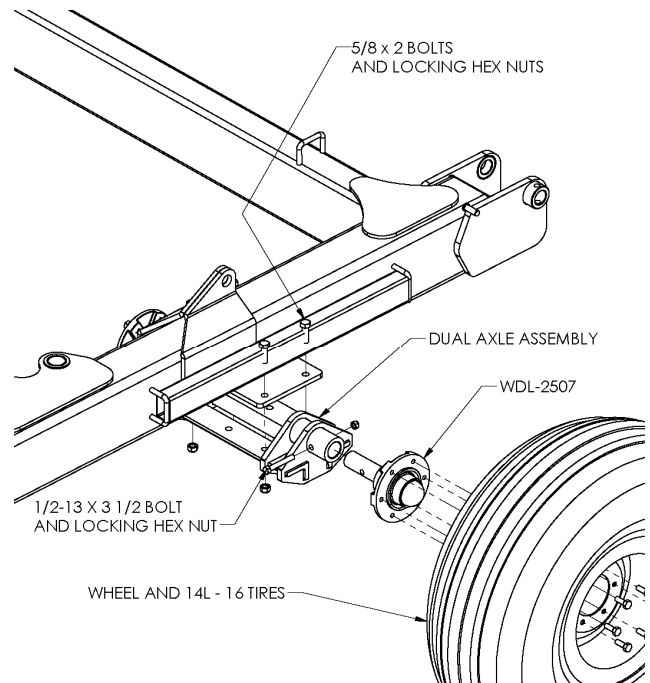

Figure 1B

Attach the Hitch, Hitch Storage Bracket, Jack and Safety Chain

4. Refer to Figure 2. Attach the 10" jack to the A-frame. Attach the base hitch and the hitch storage bracket using the 1" x 6 1/2" grade 8 bolts and locking nuts.
5. Attach the hydraulic hose clamps to the storage bracket with the 5/16 x 3 grade 5 bolt.
6. Attach the Light Plug Storage bracket to the storage bracket using the 1/4 x 1 grade 5 bolts, lock washers and hex nuts.
7. Attach the safety chain (CH-1816) using the bushing, safety chain washer, 1" x 3 1/4" grade 8 bolt and locking hex nut.

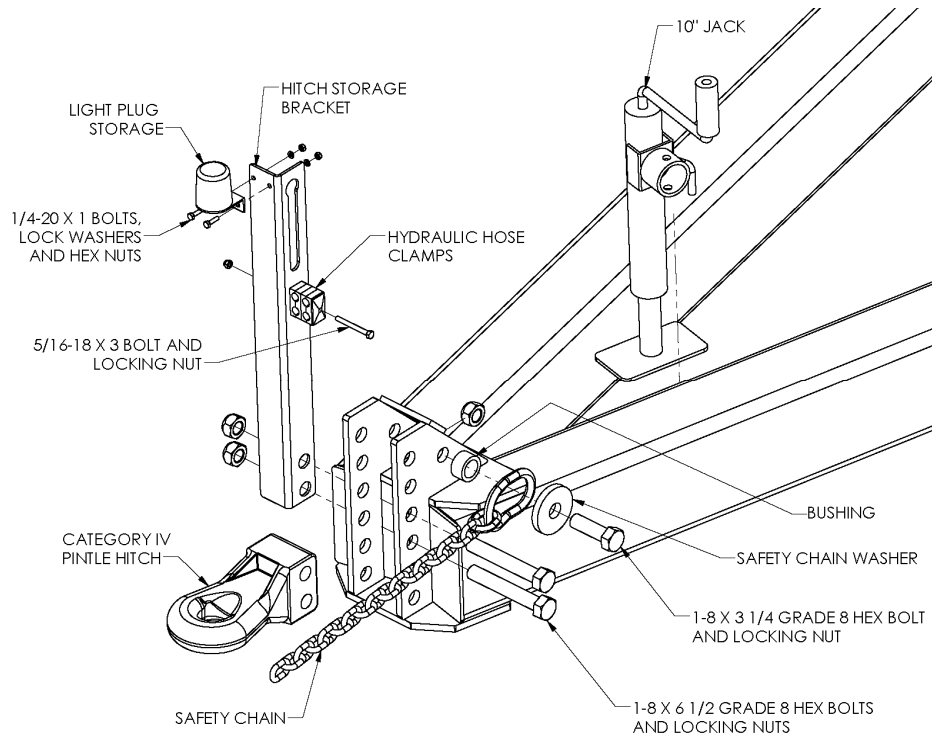

Figure 2

Attach the Center Bar to the Square Frame

1. Attach the center bar to the main frame. Refer to Figure 3. Use the 1 1/2" x 9 5/8" straight pins, 9/16" x 3 1/2" grade 5 bolts, and locking hex nuts.
2. Without using the hydraulics, attach the ASAE 16" cylinders to the cylinder posts on the main frame and to the center bar hinge plate. Note the locations of the ports and the direction of travel. Use the 1 1/4" x 6 3/4" cylinder pins with 3 holes. The extra portion of the pin should extend toward the outside of the unit.

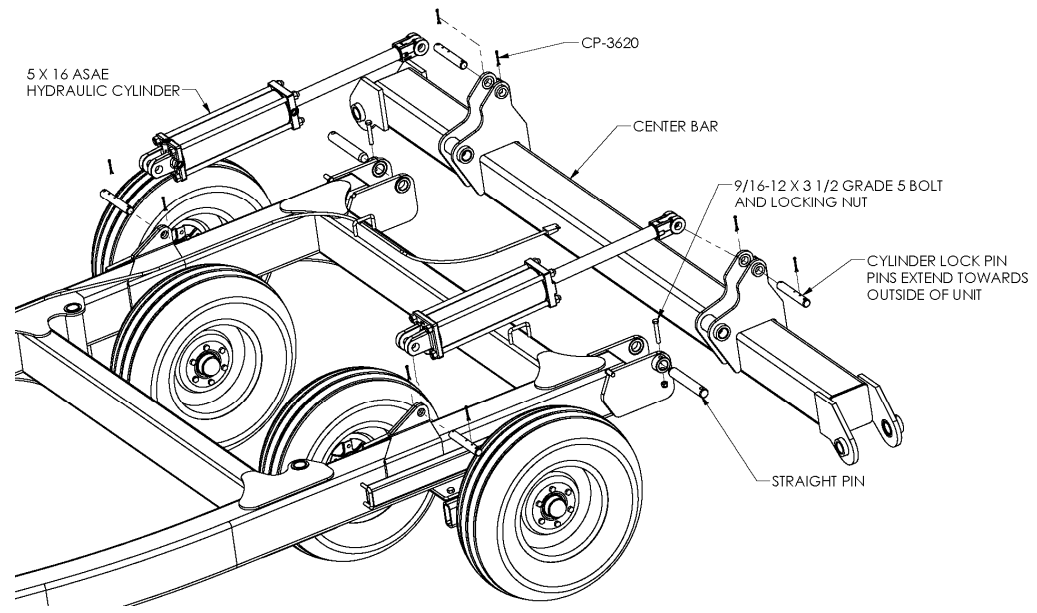

Figure 3

Install the Main Frame Hydraulics

Refer to Figure 4 and the hydraulic system diagram in appendix B for more details.

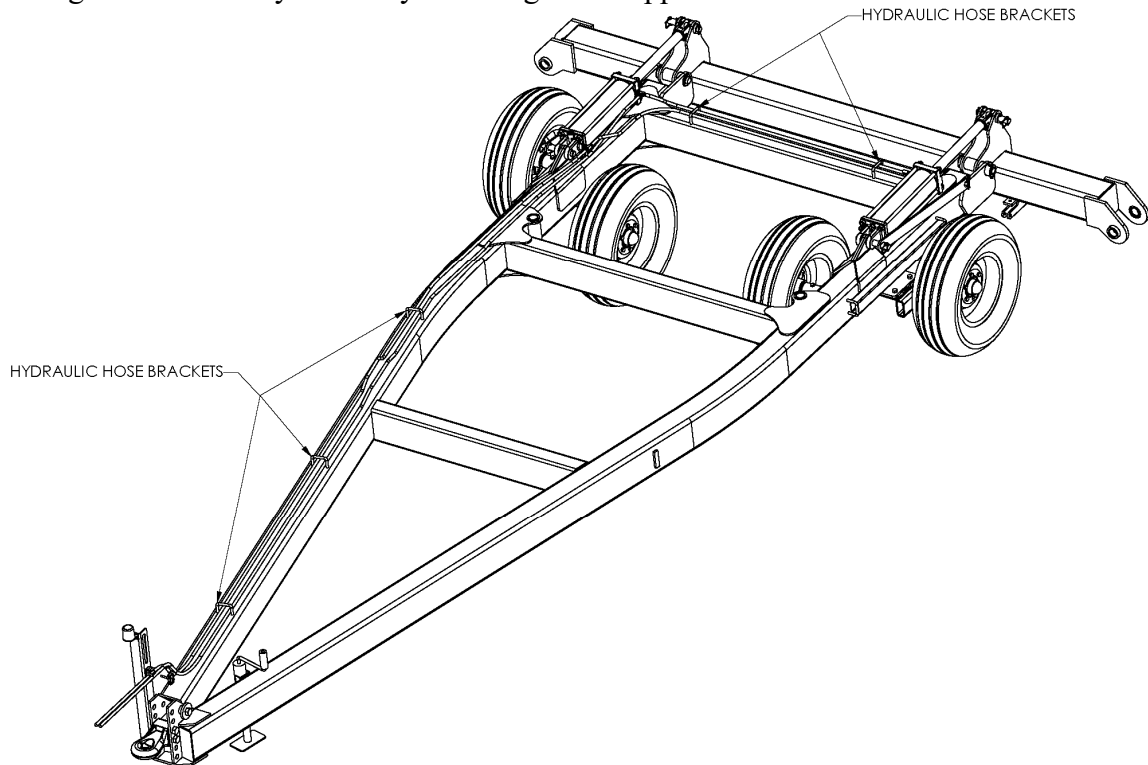

Figure 4

1. Insert all fittings into each of the ports on the cylinders. For proper placement of fittings and hoses refer to the diagram and listing in appendix B. Do *not* over tighten.
2. Connect all hoses as shown above and in appendix B. Be sure to run the hoses through the brackets that are welded to the main frame.

Before further assembly, the hydraulic system must be filled with oil. Attach the unit to a tractor and connect the hydraulic lines. Using hydraulic controls rotate the center bar and wings several times to fill the cylinders and hoses with oil.

Attach the Cylinder Lock Bars

1. Attach the slotted end of the cylinder lock bars to the base end cylinder pins using the 3/8 x 1 1/2 lynch pins. Attach the other end of the cylinder lock bars to the pins attached to the main frame using the number 9 bridge pin. See Figure 5.

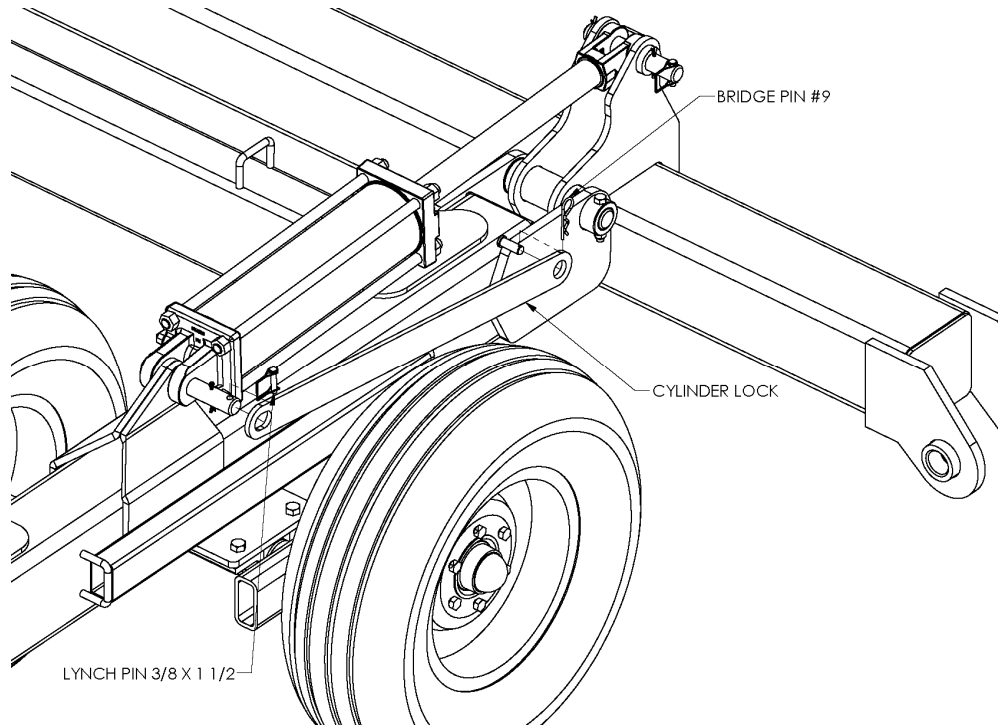

Figure 5

2. After the center bar has been rotated into the transport position remove the bridge pin securing the lock bar to the main frame and rotate the lock bar up and secure it to the rod end cylinder pin with the 3/8 x 1 1/2 lynch pin. See Figure 6.

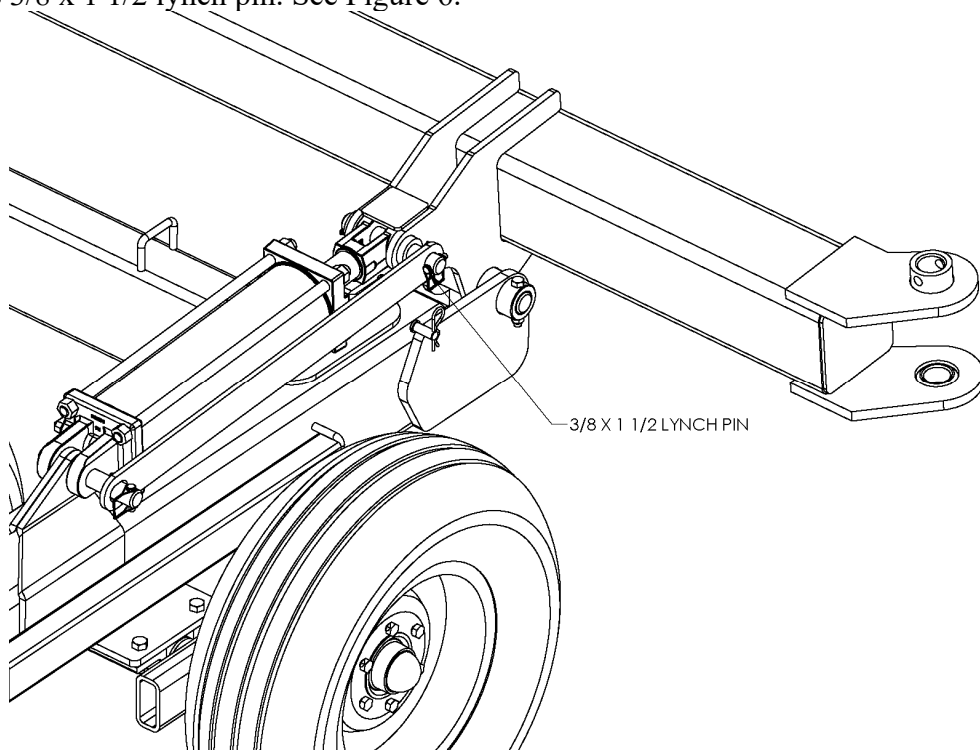

Figure 6

Attach the Wings to the Center Bar

1. Attach the hinge knuckles to the center bar. Use 1 3/4" diameter hinge knuckle pins, 5/8" x 4" grade 5 bolts, and locking hex nuts. Refer to Figure 7.
2. Attach the wings to the hinge knuckles using the remaining 1 3/4" diameter hinge knuckle pins, 5/8" x 4" grade 5 bolts, and locking hex nuts.

*NOTE: Be sure the wings are orientated correctly. Both wings are marked left hand and right hand and a visual reference can be made by looking at Figure 7 and 8.

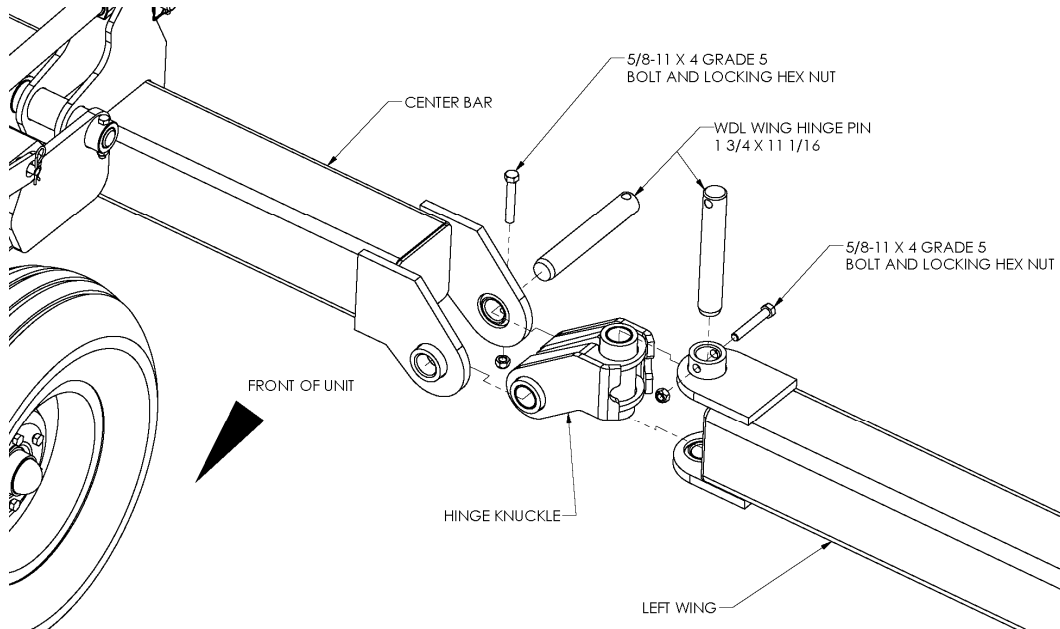

Figure 7

Attach the Wing Wheels and Tiebar Bracket

1. Mount the Tiebar Brackets to the wing tube between the cylinder post and the wing/transport wheel assemblies as shown in Figure 8. Use two 1/2 x 7 x 8 U-bolts, and locking hex nuts. The location of these brackets should be the same on the right and left hand wing tubes.

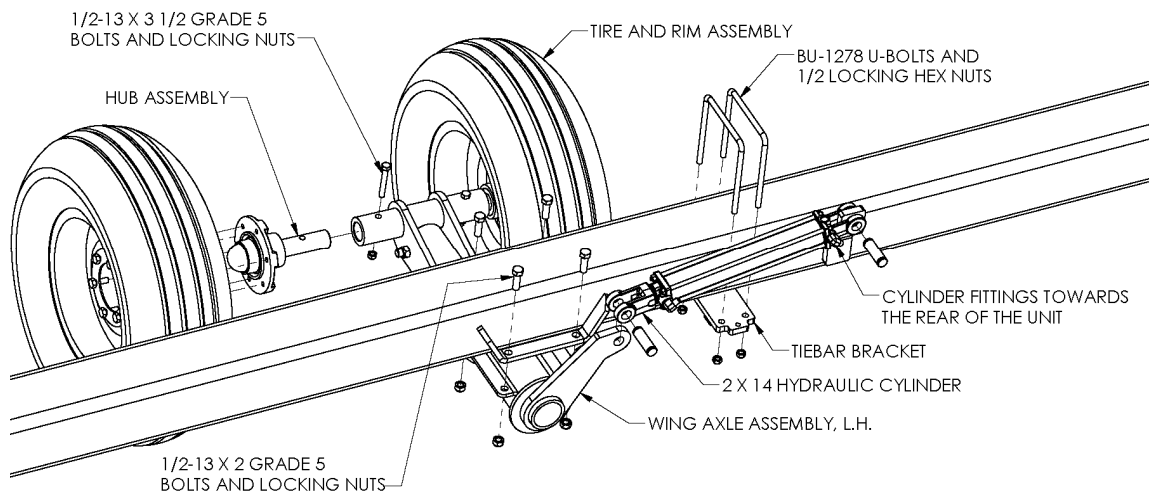

Figure 8

2. Attach the wing axle assembly to the wing tube using the 1/2-13 x 2 bolts and locking hex nuts.
3. Install the hub assemblies into the wing axle assemblies using the 1/2-13 x 3 1/2 bolts and locking hex nuts. Mount the tire and rim assemblies to the hubs.
4. Install the hydraulic cylinders as shown, with the ports facing towards the rear of the unit. The cylinder clevis may need to be adjusted in/out to ensure the tires are positioned evenly on the ground to prevent uneven tire wear.

Mount the Lift Arms

*NOTE: There are two styles of lift arms used on these units. One style (13043) has hydraulic hose clips welded to them, the other (13042) does not have hydraulic hose clips. Please refer to the layout diagrams in Appendix C for the location of these lift arms.

1. Refer to the appropriate layout diagram in appendix C. Place a mark on the center bar and wings at the locations for each of the lift arms. Be sure the dimensions are for your unit.
2. Center a lift arm on each of these marks and secure using two 1/2" x 11" bolts and locking hex nuts for each lift arm. Refer to Figure 9.

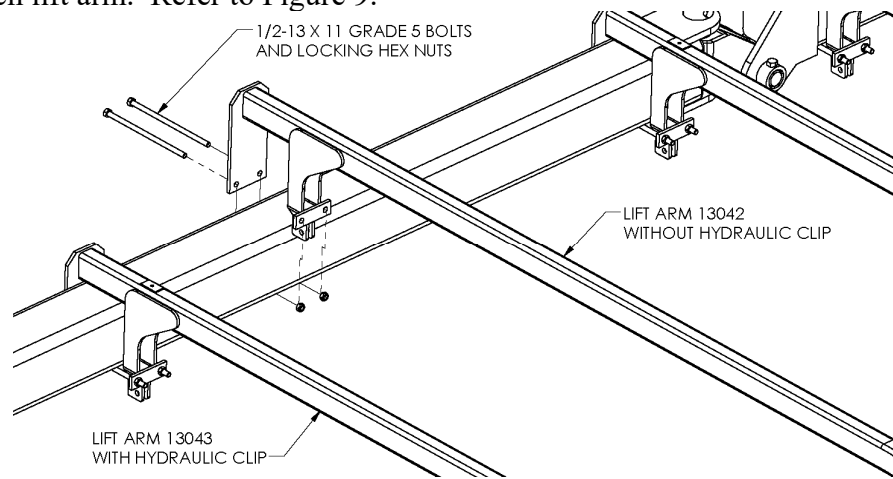

Figure 9

Attach the Pull Chains and Lift Chains

1. Bolt an 8-link pull chain (10-link for 8-bar section option) in between the lift arm pull points Use 1/2" x 2" grade 5 bolts and locking hex nuts. Refer to Figure 10.

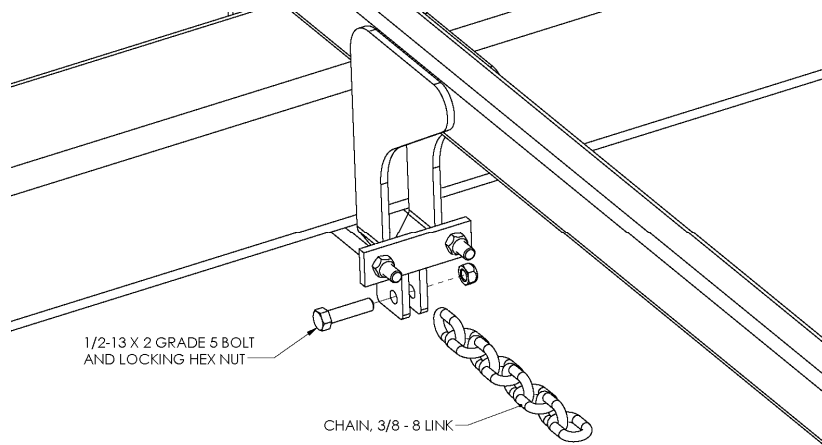

Figure 10

2. Bolt an 8-link lift chain between the chain tabs at the rear end of each lift arm. Use 1/2" x 2" grade 5 bolts and locking hex nuts. Refer to Figure 11.

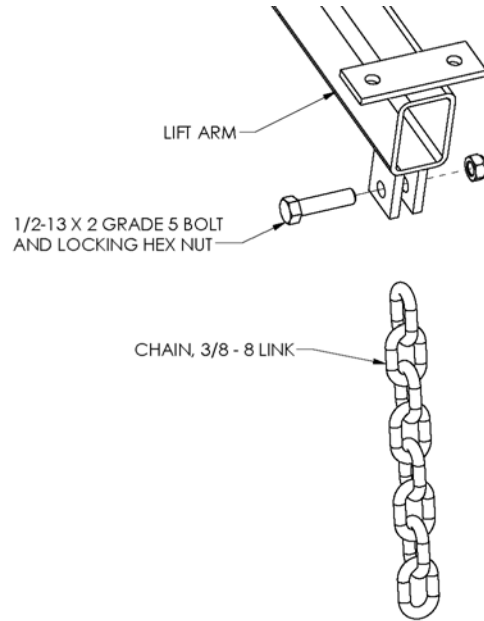

Figure 11

Attach the Wing Jack Plates

1. Attach the wing jack plates to the wing tubes. Use 5/8-11 x 7 x 8 1/2 U-bolts and locking hex nuts. Edge of Wing Jack Plate should be 18" from end cap of wing tube. Refer to Figure 12.

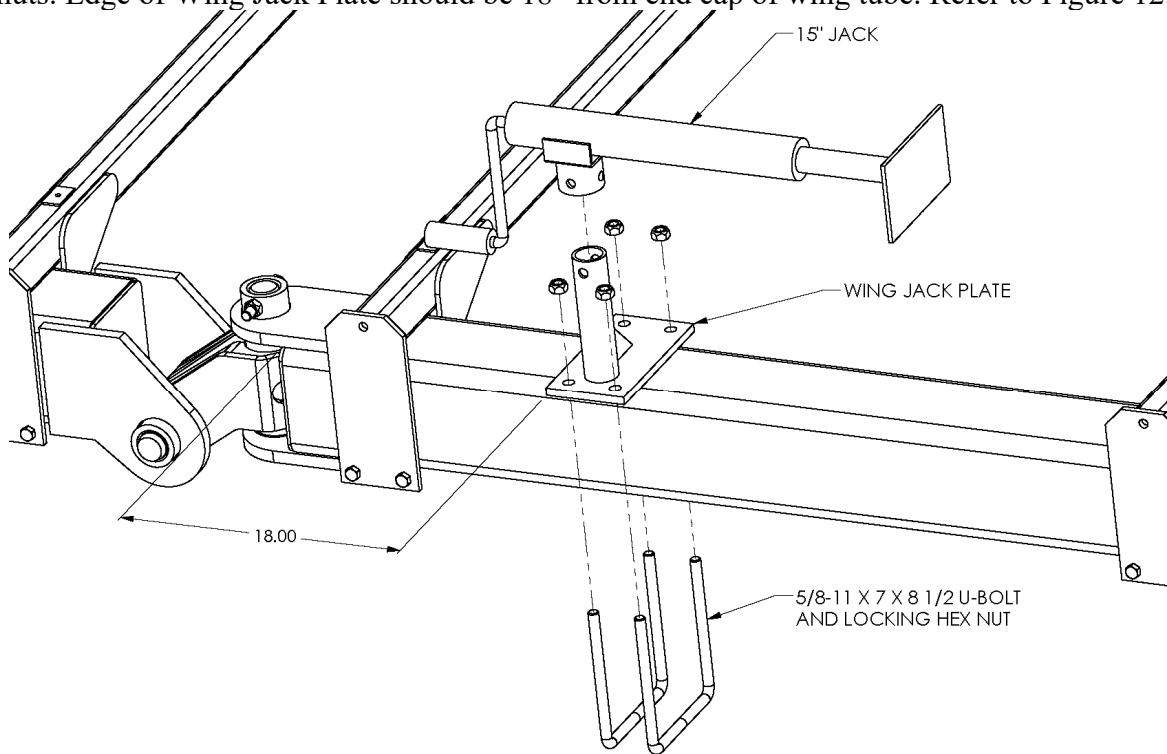

Figure 12

Attach the Tie-Bar

1. Secure the outside tie-bar half to the tiebar bracket installed earlier in assembly using the 3/8 x 2 1/2 lynch pin/ Refer to figure 13.
2. If not already done, slide the inside tie-bar half inside of the outside tiebar half.
3. Attach the tie bar bracket to the wing toolbar using the 1/2-13 x 7 x 8 1/4 U-bolts and locking hex nuts
4. Secure the inside tie-bar half to the tiebar bracket using the 3/8 x 2 1/2 lynch pin.

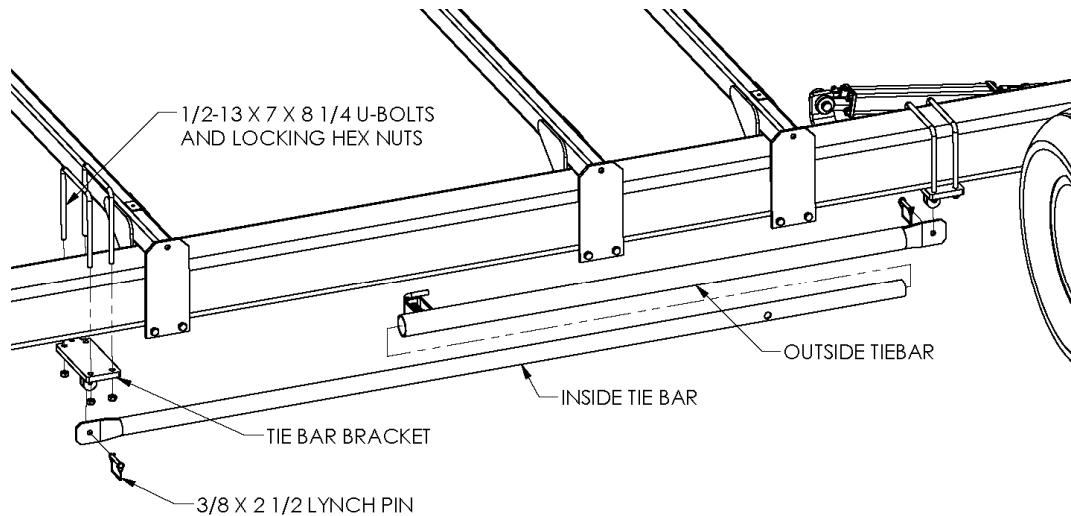

Figure 13

Install the Transport Hydraulics

Refer to Figures 14, 15, 16 AND 17

*Note: For the hydraulics layout refer to the diagram in appendix B.

1. Run the 3/4" hoses (12554) along the right side of the main frame back to the center bar. Go through the hose brackets on the main frame following the hoses for the main frame cylinders.
2. Bolt the hydraulic hose tee post to the center bar, centered on the center bar. Use 1/2 x 7 x 8 1/4 U-bolts and locking hex nuts.
3. Attach the hydraulic tees to the tee brackets by inserting the long leg of a tee through the tee bracket and securing with a tee nut.
4. Each side gets one of the longer and one of the shorter of the hoses remaining. Both longer hoses connect to one of the Tees and both the shorter hoses connect to the other Tee. The hoses should pass through the hydraulic hoses clips that are on the lift arms.
5. Connect hoses to the wing wheel cylinders. The longer hoses should be connected to the rod end of the cylinders and the shorter hoses should be connected to the base end of the cylinders. Be sure the hoses will not catch on the rotating transport wing wheel axle assemblies when the cylinders are actuated.
6. Attach the transport cylinder locks to the tiebar bracket. Using the 3/8 x 2 1/2 lynch pin.
7. Be sure to pull the slack from both ends of the hoses to the gap between the last center bar lift arm and the first wing lift arm. Be sure the hoses will not catch on any moving parts and that

there is enough slack between the center bar and the wing to allow the unit to be folded into the transport position.

8. Attach the 348" main frame hoses (12554) to the tees on the center bar. Route the hoses through the hydraulic brackets on the main frame along with the main frame hydraulic hoses. Be sure there is enough slack in the rear for the center bar to rotate.

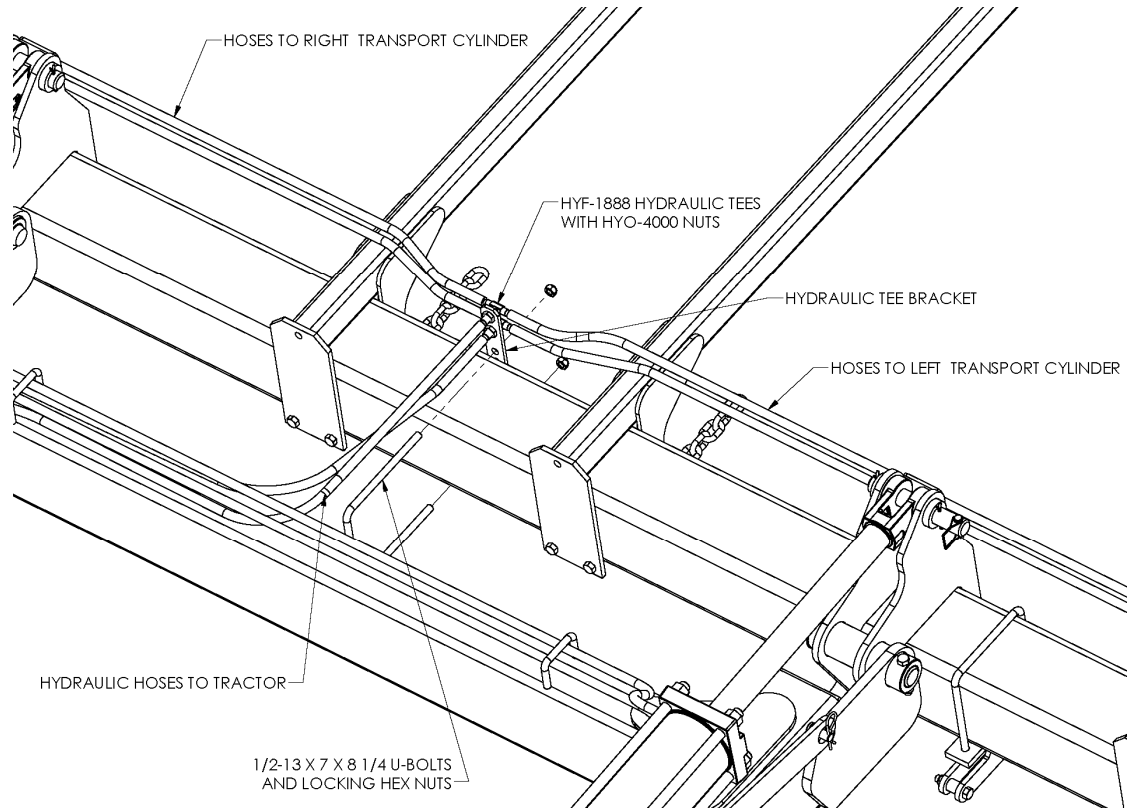

Figure 14

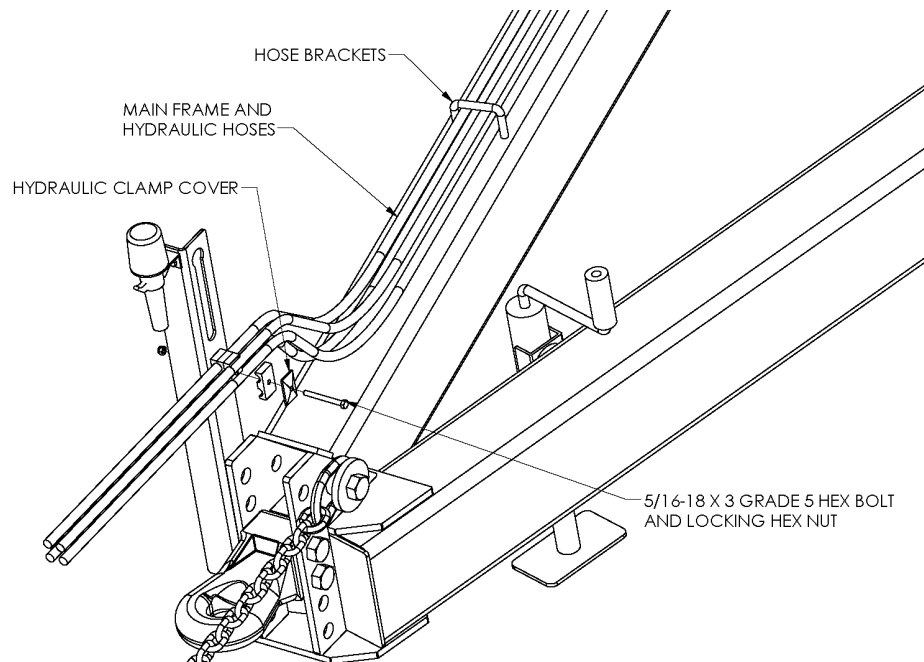

Figure 15

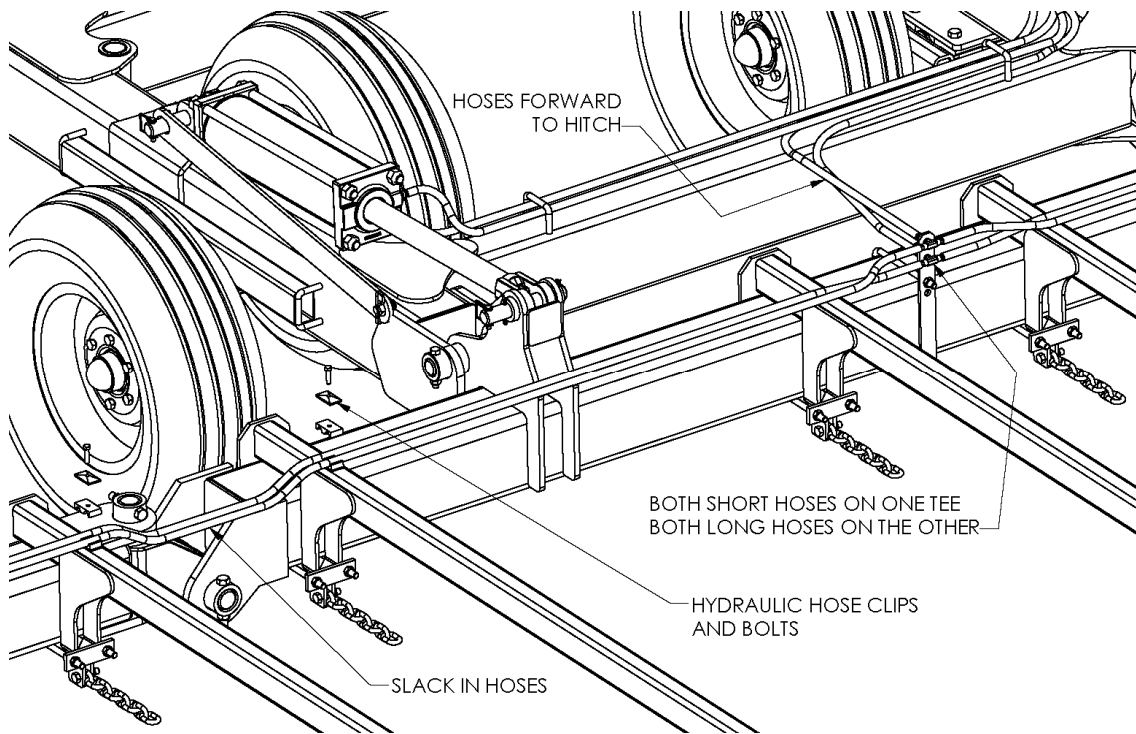

Figure 16

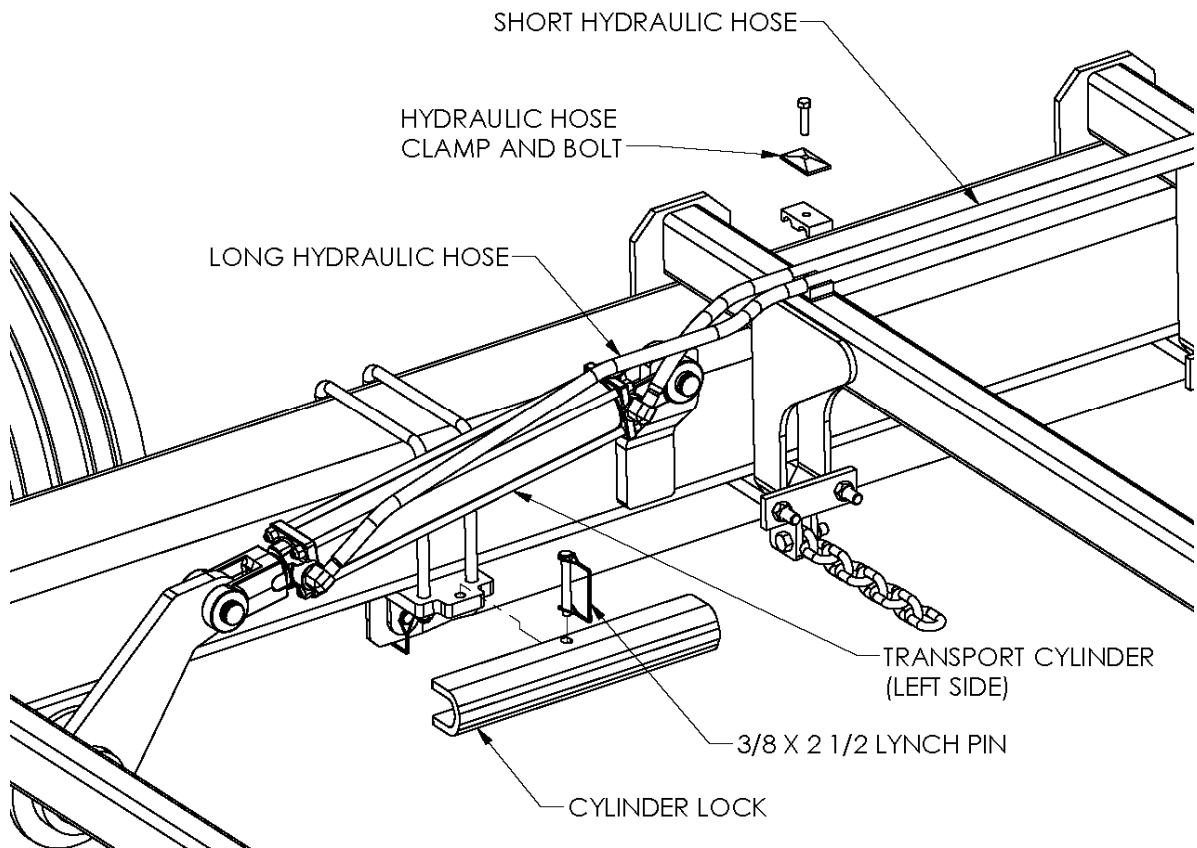

Figure 17

Attach the Pivot Arm Assemblies

Slide the pivot arm assemblies into the pivot bushings on the Main Frame. Secure in place with the lock bushing, 1/2-13 x 3 1/4 grade 5 bolts and locking hex nuts.

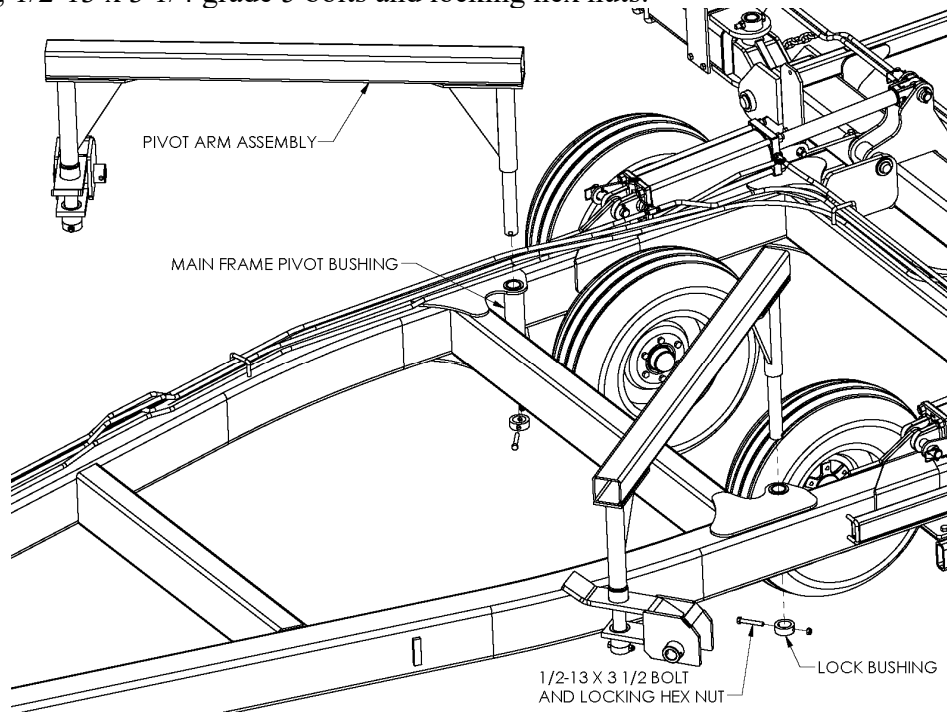

Figure 18

Attach the Lock Bracket Assemblies

Attach the Lock Bracket assemblies to the Main Frame using the 5/8-11 x 8, grade 8 bolts, locking hex nuts and the WD-2912 clamp plates. Make sure to mount the assembly against the stop tab welded on the side of the Main Frame. Do not tighten yet. Refer to Figure 19.

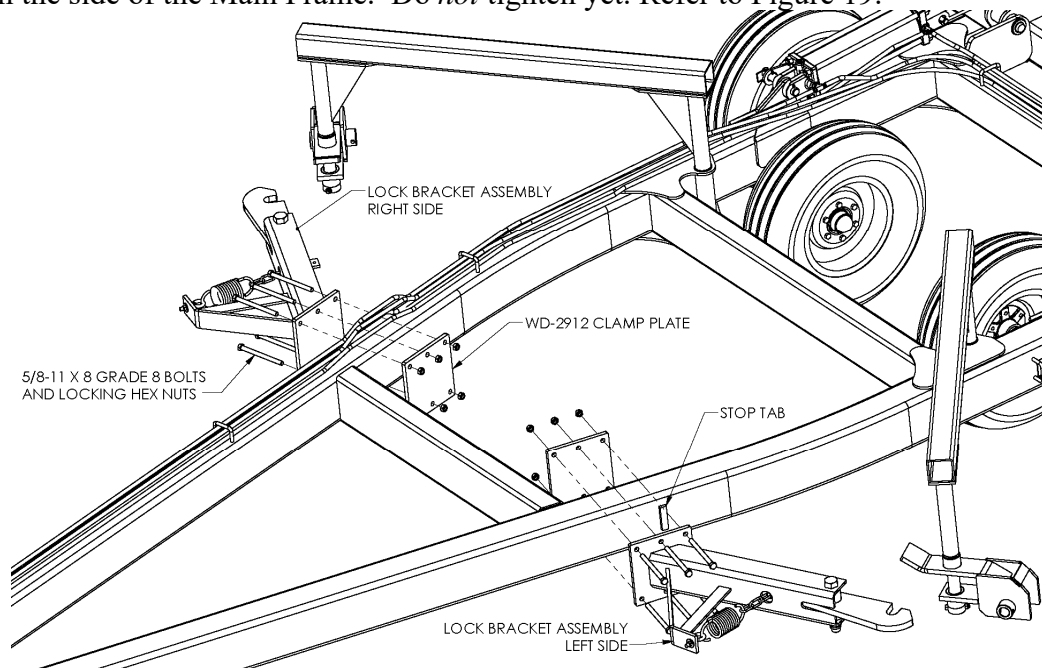

Figure 19

Attach the Cable Brackets

1. Attach the cable bracket to the center bar 5" from the cylinder hinge plate. Refer to Figure 20. Use two 1/2-13 x 7 x 8 1/4 U-bolts and locking hex nuts.
2. Repeat on the other side of the cart.

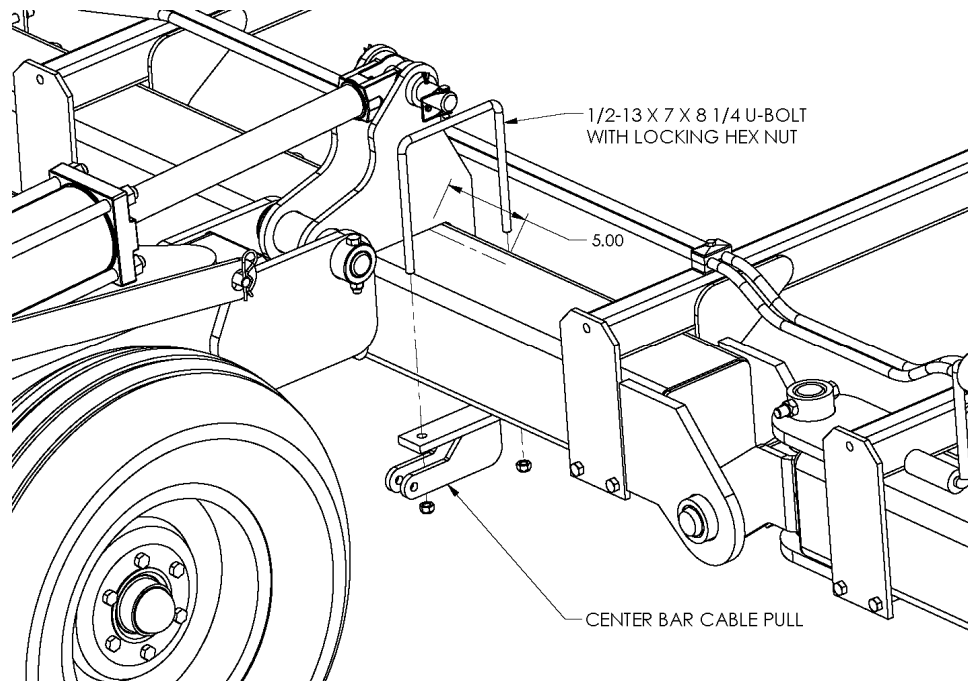

Figure 20

Install the Cables

NOTE: Outside wheel and tire assembly removed for better visual clarity.

1. Slide a 3/8" cable through the frame cable guide tube. Refer to Figure 21.
2. Attach the cable to the bracket on the center bar. Use a 1/2-13 x 2 1/2 grade 5 bolt and locking hex nut and bushing.
3. Connect a 9-link chain to the other end of the cable with a quick-link. Refer to Figure 22.
4. Secure the last link of the chain to the lock arm tab with a shackle.
5. Repeat on the other side.

The cables must have slack when in the field position to allow for the center bar to rotate before unlocking the lock bar mechanism. The chain length will be adjusted when assembly is complete

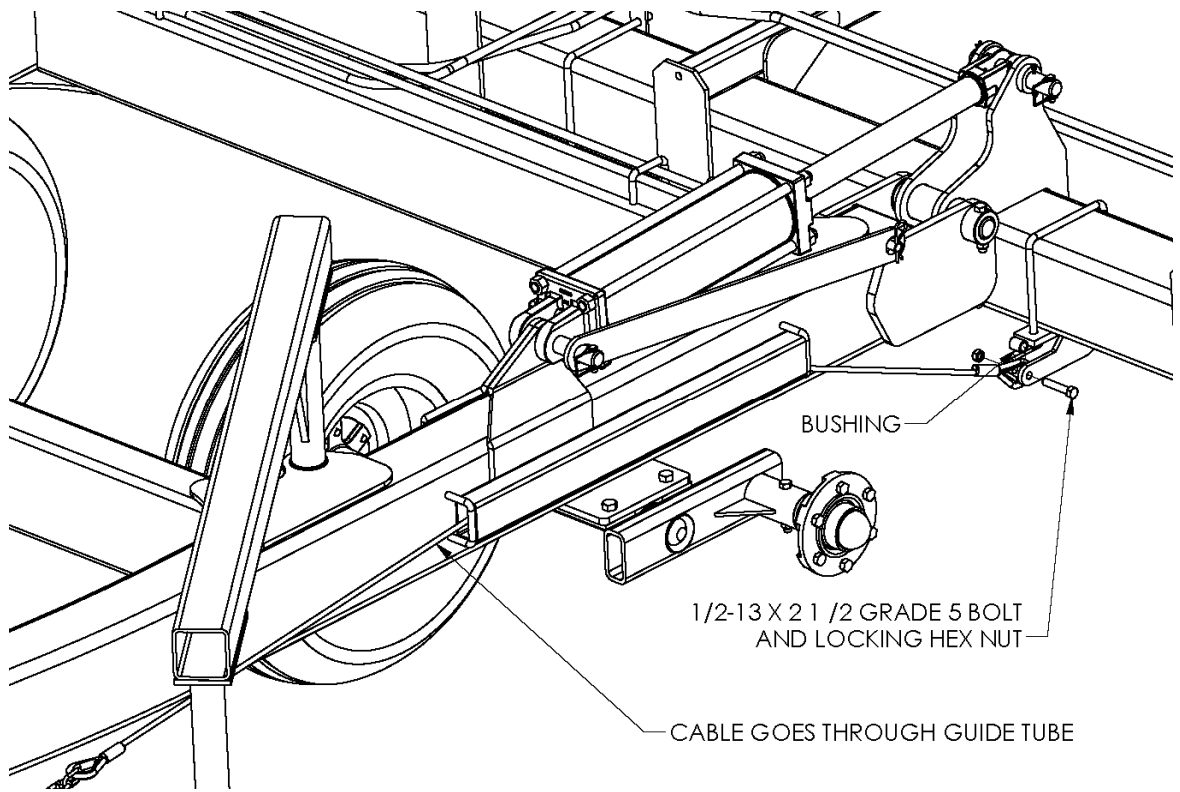

Figure 21

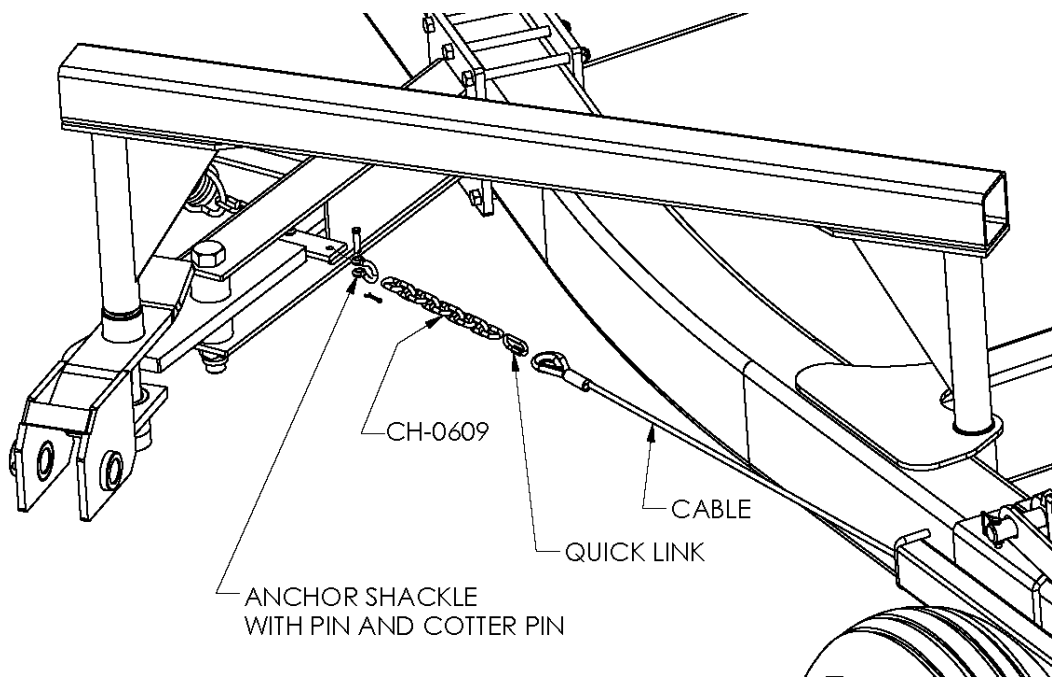

Figure 22

Attach the Main Pull Tube to the Pivot Bracket

1. Attach the main pull tubes to the pivot brackets with the 1 1/2" x 8 5/16" pin. Refer to Figure 23
2. Secure the pin with a 1/2" x 3 1/4" grade 5 bolt and locking hex nut.

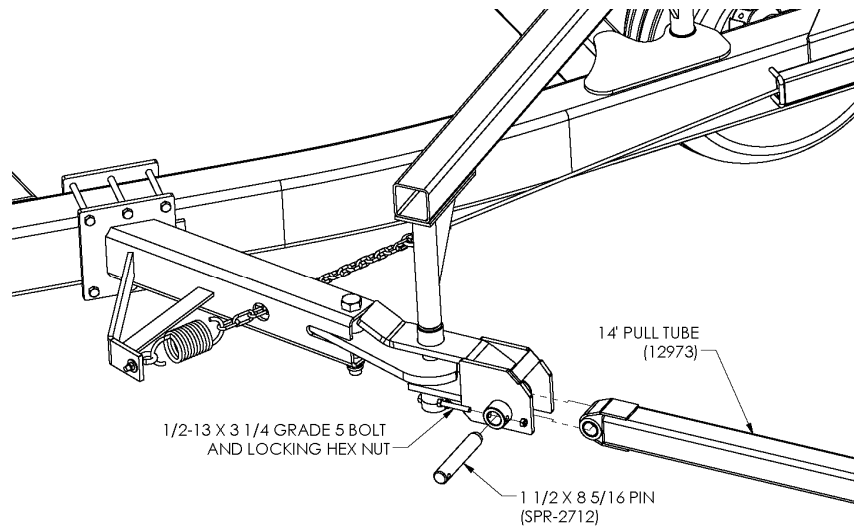

Figure 23

Attach the Main Pull Tubes to the Wing Anchor Bracket

1. Be sure the wing is in line with the center bar. Using the pull tube as a guide, attach the main pull tube anchor assembly to the wing in the approximate position shown in Figure 24. Use eight 3/4-10 x 10, grade 8 bolts and locking hex nuts and a clamp plate. Do not tighten bolts yet. Attach the pull tube to the wing anchor bracket with the 3/4-10 x 5, grade 5 bolt and locking hex nut and the 5/8-11 x 4 grade 5 bolt and locking hex nut with the bushings and pin as shown. After all components have been assembled tighten all fasteners securely.

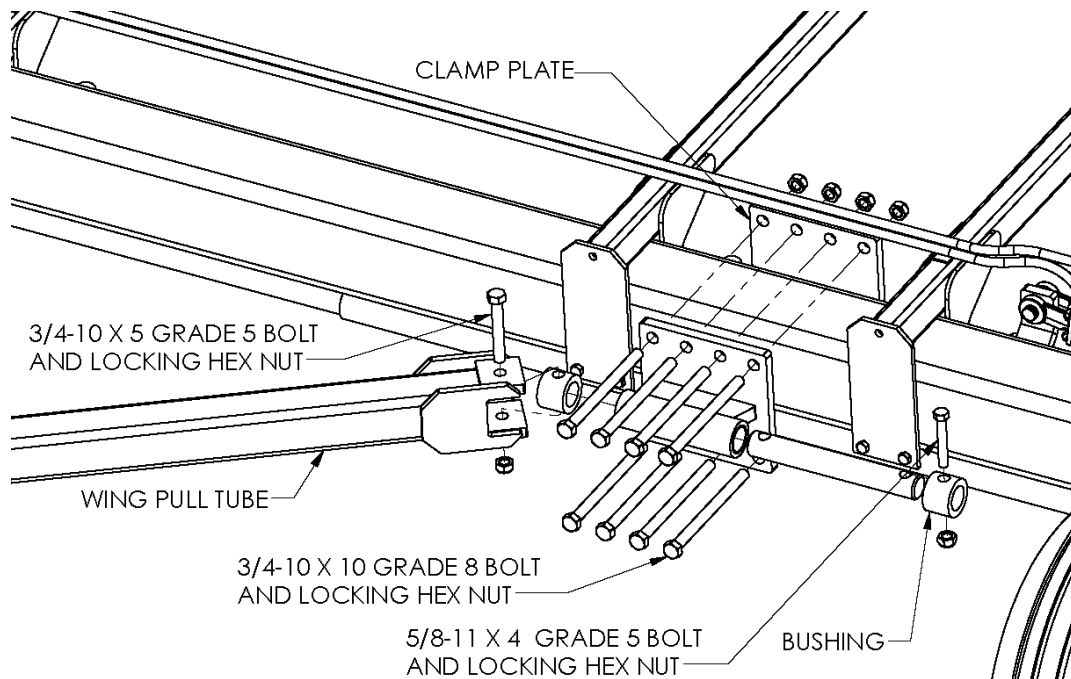

Figure 24

Cable Adjustment

Slowly rotate the center bar into the transport position. Be sure the locks do not release before the lift arms reach about a 45° angle. *If the lock bar unlocks too early in the lifting procedure, the lock will be damaged.*

If the center bar rotates all the way up and the locks do not release, the chains connecting the cables and the lock arms must be shortened. Shorten the chains one link at a time until the lock bars release as soon as the sections have been lifted off the ground and the lift arms reach about 45° angle.

Light Kit Installation

Refer to Figures 25, 26 and 27

1. Connect the wishbone extension (3 pin plugs on each end) to the wishbone harness (four pin plug in the middle and 3 pin plugs at each end). Depending on model size, there may be one or 2 wishbone extension harnesses.
2. Lay out the wishbone and wishbone extensions on the toolbar. The plug on the wishbone harness will be in the center of the unit and the light harnesses will generally follow the transport cylinder hydraulic hoses. The three pin plug connects to the lights. Be sure to leave approximately 2' extra to run up the lift arm to attach to the lights. Do not attach to the frame.
3. Lay out the extension harness (seven pin connector on one end and a 4 pin connector on the other end) by plugging it into the wishbone harness that is laid out across the front of the lift arms. Working towards the hitch, following the hydraulic hoses, and going through the hydraulic hose brackets up to the hitch. Secure the wire harness to the hydraulic lines periodically with electrical ties. Make sure there is plenty of slack to connect to the towing vehicle.

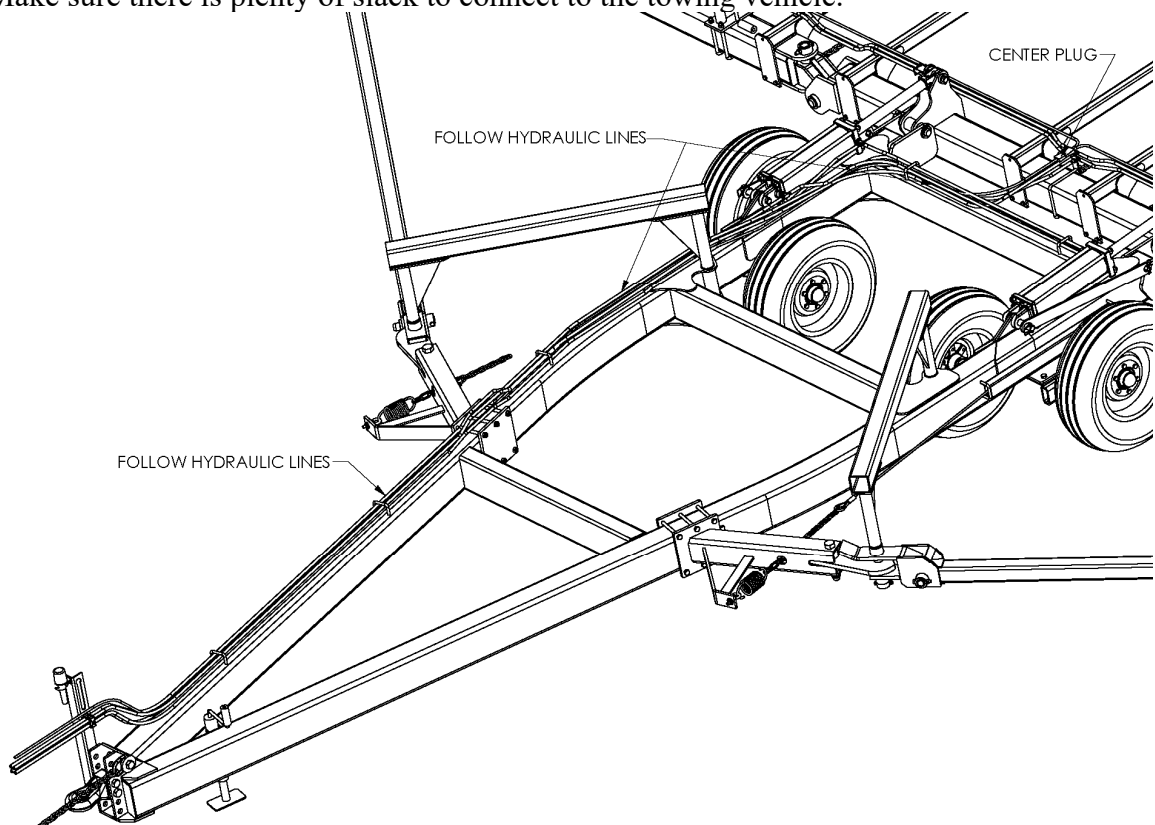

Figure 25

4. Attach the lights to the mounting brackets using 1/4 x 1 bolts, lock washers and hex nuts.

- Attach the light assemblies to the last lift arm on the wings using the 3/8 x 2 - 3 3/4 U-bolts and locking hex nuts. Dimension from the front of the Light Bracket to the front of the lift arm tube is approx. 16 inches. Do not tighten yet. You may have to adjust the location later. The lights must be attached so that the red and yellow lenses will be facing away from the center of the unit with the yellow light towards the rear of the unit. The single yellow lens will be towards the center of the unit, facing towards the center of the unit. Connect the free end of the wishbone to the lights.

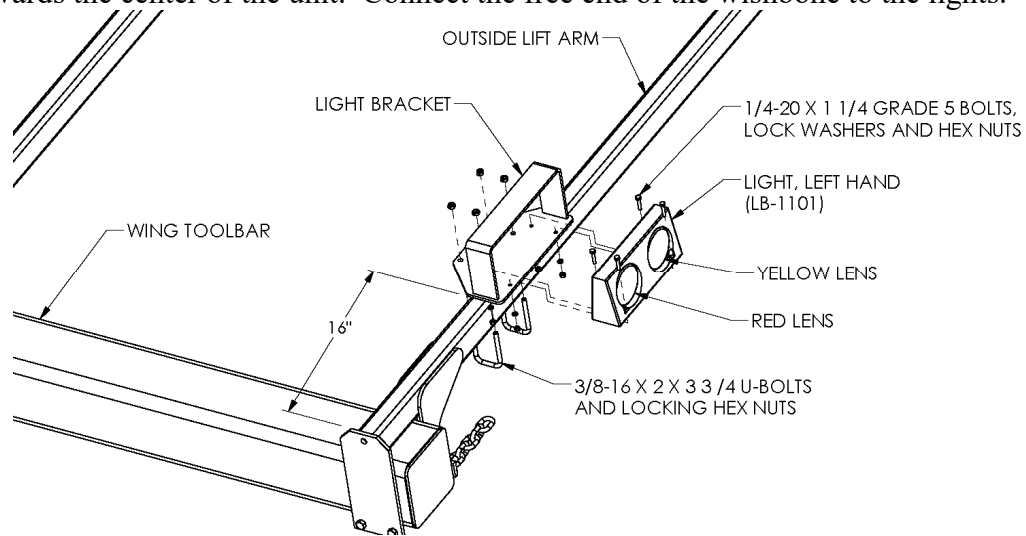

Figure 26

- Now that the lights have been mounted and the wires run, attach wire harnesses to the lift arms and hydraulic hoses with zip ties. Be sure to leave slack at the hinge points to prevent the wire harness from becoming entangled. Also, securely attach the wire harness to the lift arm and next to the light assembly.
- Tighten the light assemblies to the lift arms.
- Check to make sure that all the plugs are properly and securely connected and the wire harnesses will not become entangled during operation or when the unit is folded into transport position.

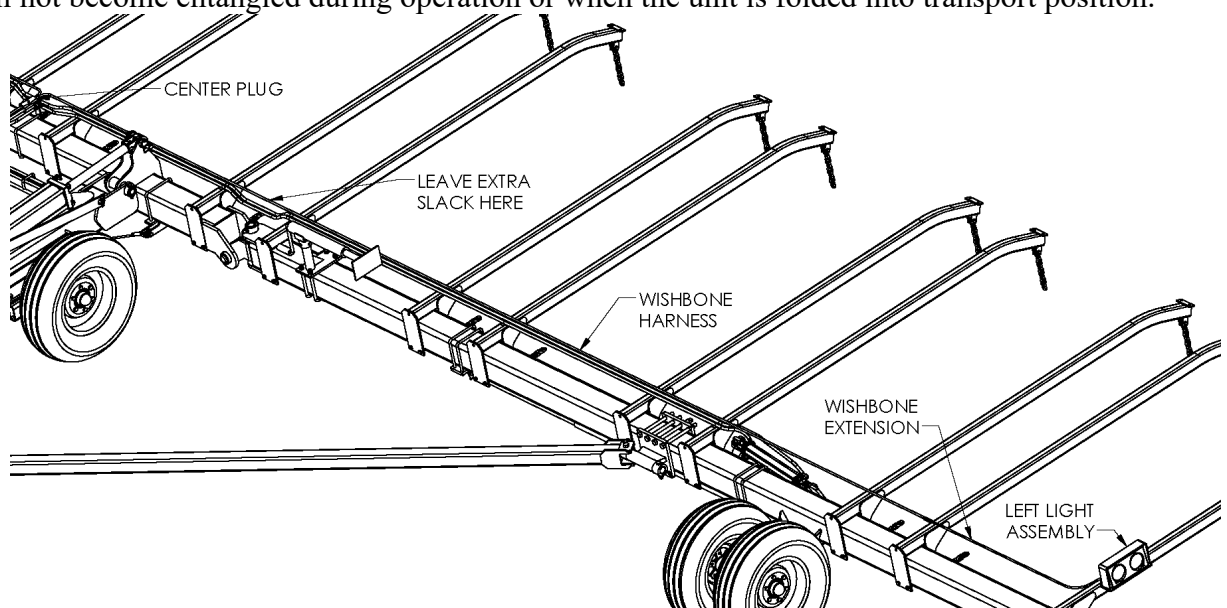

Figure 27

9. Attach the unit to a tractor and plug in the lights. Check to make sure that they are working properly and that the wires do not pull or get caught when folding the unit into the transport position. With the unit in transport position, the red and yellow lights should be visible from the rear. The red light should be closest to the ground.

Slow Moving Vehicle Sign Installation

Using the 3/8-16 x 2 x 3.75 U-bolts with locking hex nuts attach the SMV Mount Bracket to the left side outside lift arm as shown in Figure 28.

Mount 48 inches from front of SMV mount bracket to the front of the lift arm tube.

Attach the Slow Moving Vehicle (SMV) sign to the mount bracket using the 1/4-20 x 1 bolts with lock washers and hex nuts.

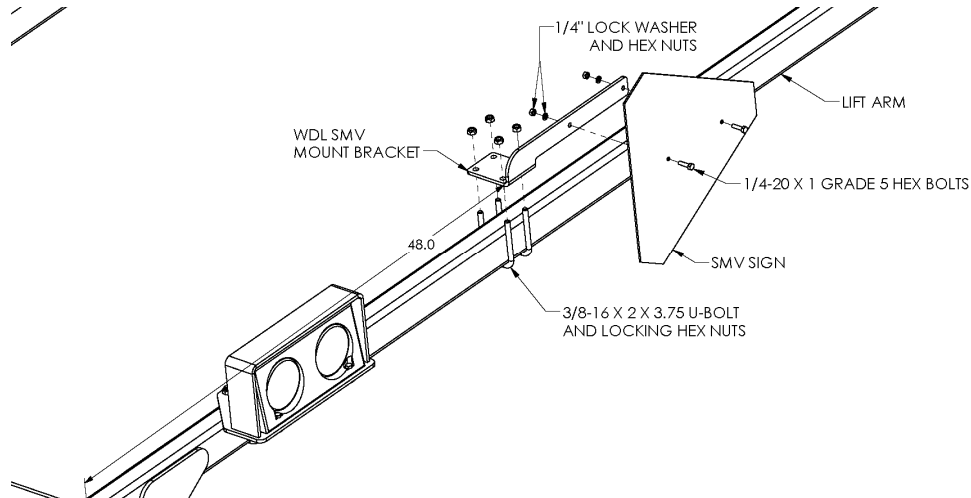

Figure 28

Attach the Stabilizer Angles

Refer to the layout diagrams in appendix C for the locations of the different lengths of stabilizer angles. Bolt the stabilizer angles to the bolt plates near the rear end of the lift arms. Refer to Figure 29. Use 7/16" x 1 1/4" grade 5 bolts and locking hex nuts.

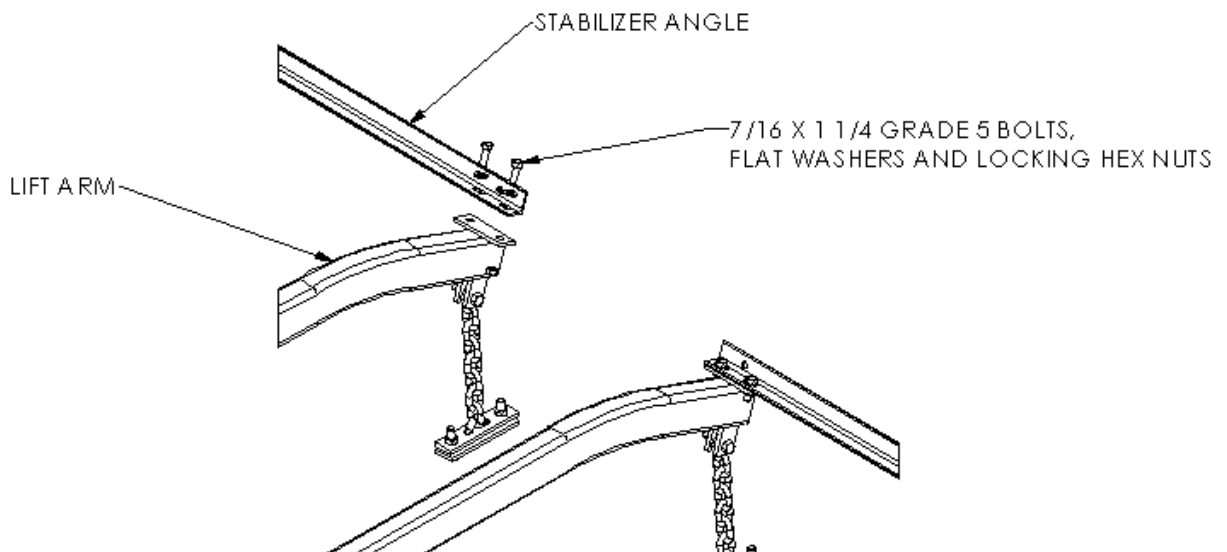

Figure 29

Angle of Attack

Before placing the harrows, you will want to determine the 'angle of attack' desired for your particular application. Refer to Figure 30 to help clarify what is meant by 'angle of attack.' McFarlane flexible harrow sections have a built-in system which allows the harrow owner a choice between a steep or shallow angle of attack. To change the angle of attack, simply reverse the harrow section and pull it from the other end.

Each angle has its advantages and disadvantages. The steeper angle of attack is for more aggressive harrowing. However, the steeper the angle, the greater the tendency there is for the sections to clog with field debris.

Be sure all adjoining harrow sections are set to the same angle. Each section is matched to the one next to it and may become entangled if the angle settings do not match. It may be desirable to set the front sections (8-bar on a 16-bar harrow) aggressive and the rear sections less aggressive.

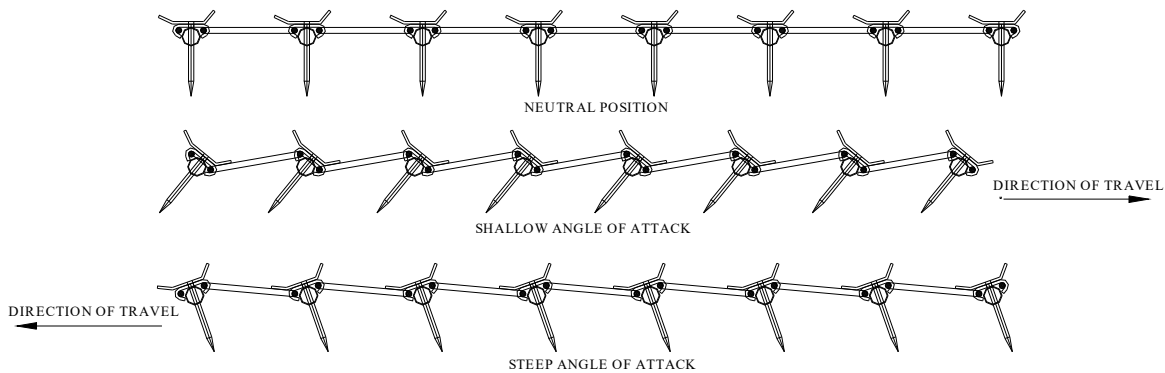

Figure 30

Harrow Identification

The number of teeth on a bar is the same as the first digit of the harrow identification number. The last number is the number of bars per section. An FH-600-8 would have six teeth per bar and 8 bars; an FH-800-8 would have eight teeth per bar and 8 bars.

Harrow Configurations

McFarlane harrow sections may be attached in any one of several distinct configurations: 8-bar, 4+4-bar, 12-bar, 6+6-bar, 16-bar, and 8+8-bar. The 8, 12, and 16-bar harrow configurations utilize a single set of pull points located adjacent to the center bar and wings.

The 4+4, 6+6, and 8+8-bar harrow configurations (also known as dual sections) also utilize a second set of pull points located at the rear end of the lift arms. Persons assembling an 8, 12, or 16-bar harrow should **ignore** the instructions in *italics* describing the attachment of the rear pull points. Those assembling a dual section harrow should be sure to **follow** the instructions for attaching the rear pull points in *italics*.

Attach the Harrow Sections

Now that you have determined the desired angle of attack and identified the harrow sections, position the harrow sections on the ground under each pair of lift arms. Refer to the layout diagrams in appendix C to determine the placement of the harrow sections.

Instructions follow for attaching the harrow sections. Be sure to follow the instructions corresponding to your configuration. Note that if the unit includes the heavy-duty center harrow section option, place those sections first. Refer to the setup instructions for these sections.

Connect an 8-Bar Section

1. Bolt the pull chains to the front tabs on the harrow sections. Refer to Figure 31.
Use 1/2" x 1 1/2" bolts, flat washers and locking hex nuts. The chains should be bolted to the bottom of the pull tabs. Make sure that the chains are not twisted.

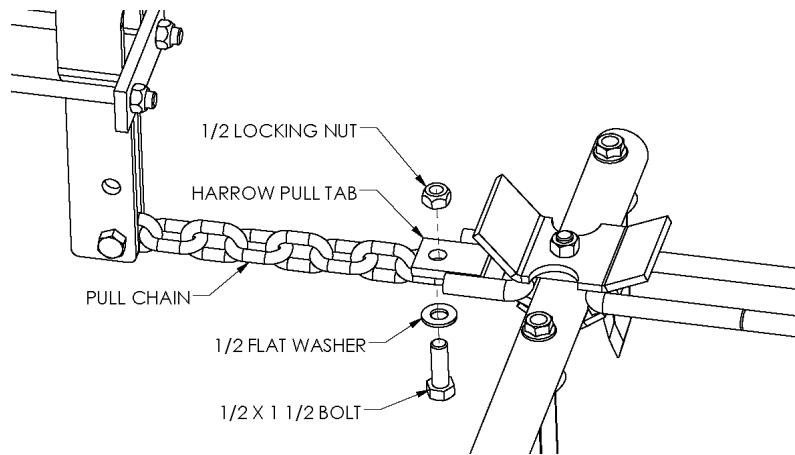

Figure 31

2. Bolt the lift chains to the bottom of the rear lift tabs of the harrow sections. Refer to Figure 32.
Use 1/2" x 1 1/2" bolts, flat washers, and locking hex nuts. Make sure the chains are not twisted.

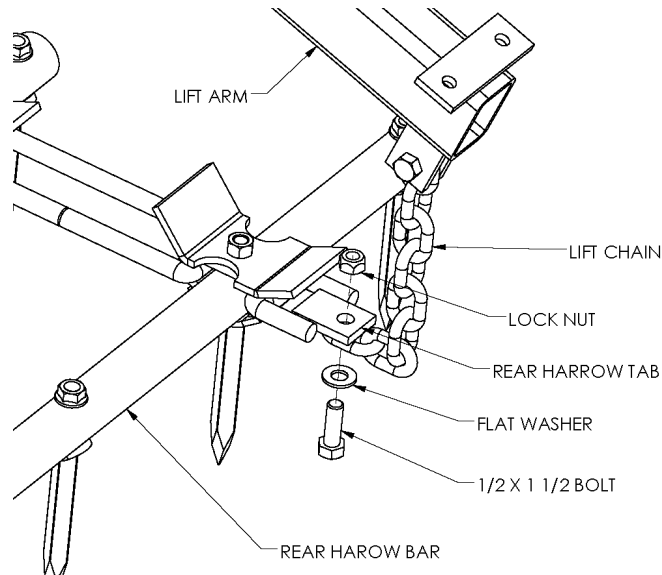

Figure 32

Connect a 12 or 16-Bar Section

1. Bolt the pull chains to the front tabs on the front harrow sections. Refer to Figure 31. Use 1/2" x 1 1/2" bolts, flat washers, and locking nuts. The chains should be bolted to the bottom of the pull tabs.
2. Bolt the front and rear harrow sections together using two 5/16" x 1 1/2" x 6" dual section connector links at each pull tab. Refer to Figure 33. Use two 1/2" x 2" bolts and locking hex nuts. Do *not* tighten yet.
3. Bolt the lift chains to the dual section connector links. Use one 7/16" V-bolt and two lock nuts on each link. Tighten all dual section connector link bolts.
4. Make sure that the harrow sections match each other, the angle of attack is correct, and the chains are not twisted.

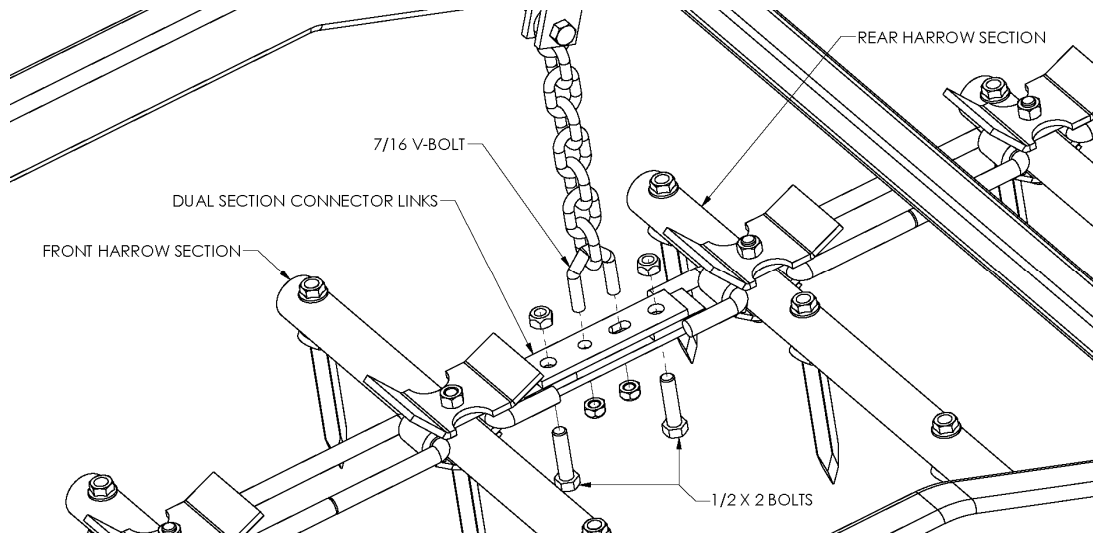

Figure 33

Attach the Rear Pull Points

1. Attach a rear pull point assembly to the rear end of each lift arm. Use four 1/2" x 3" bolt and lock nuts. Refer to Figure 34.
2. Bolt an 8-link pull chain to the end of the rear pull point assembly with a 1/2" x 2" bolt, lock washer, and hex nut. Refer to Figure 34.

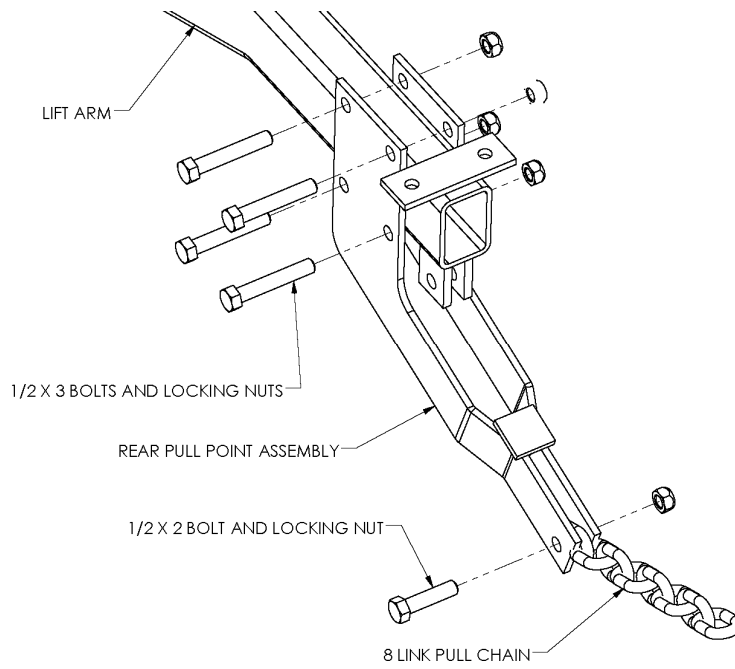

Figure 34

Connect 4+4, 6+6 or 8+8 Sections

1. Bolt the pull chains to the front tabs on the harrow sections. Refer to Figures 31 and 35. Use 1/2" x 1 1/2" bolts, and locking hex nuts. The chains should be bolted to the bottom of the pull tabs.
2. Bolt the lift chains to the bottom of the rear lift tabs of the front harrow sections. Refer to Figure 32. Use 1/2" x 1 1/2" bolts, flat washers, and locking hex nuts.
3. Make sure that the harrow sections match each other, the angle of attack is correct, and the chains are not twisted.

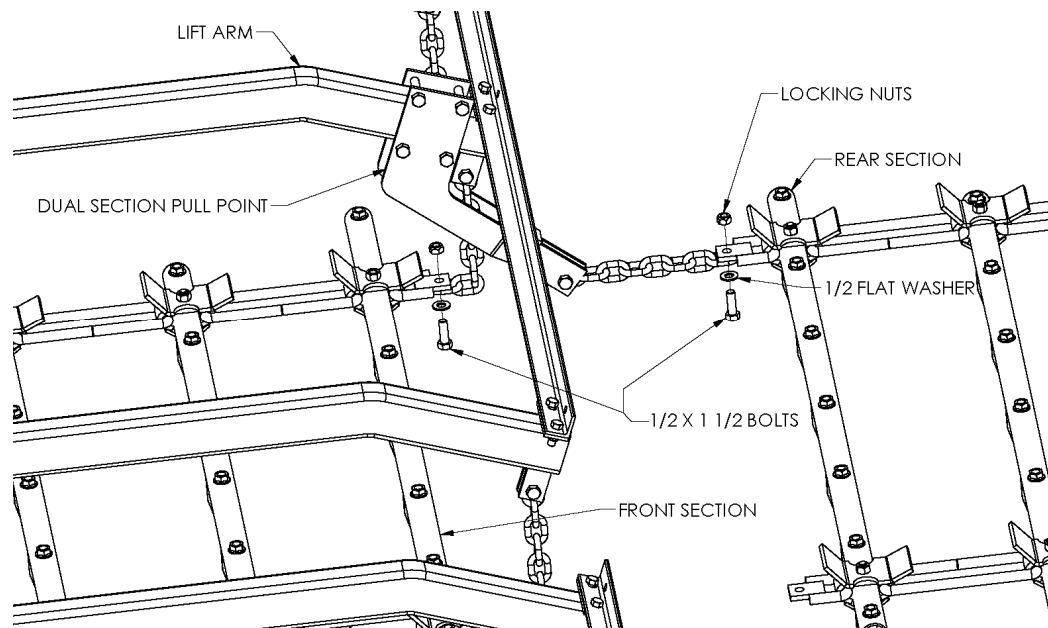

Figure 35

Connect Heavy-Duty Center Section Option

1. Bolt the lift chains to the rear pull point of the front FA harrow sections. Be sure to attach it to the top hole as shown. See figure 36. Use 1/2" x 1 1/2" bolts, square washers and lock nuts. Note that the FA section is shown in the more aggressive position.
2. Attach the rear harrow sections on the center bar to the front FA harrow sections. Bolt the pull chain to the bottom hole of the rear pull point of the FA section. Use 1/2" x 1 1/2" bolts, flat washers, lock washers, and hex nuts as shown.

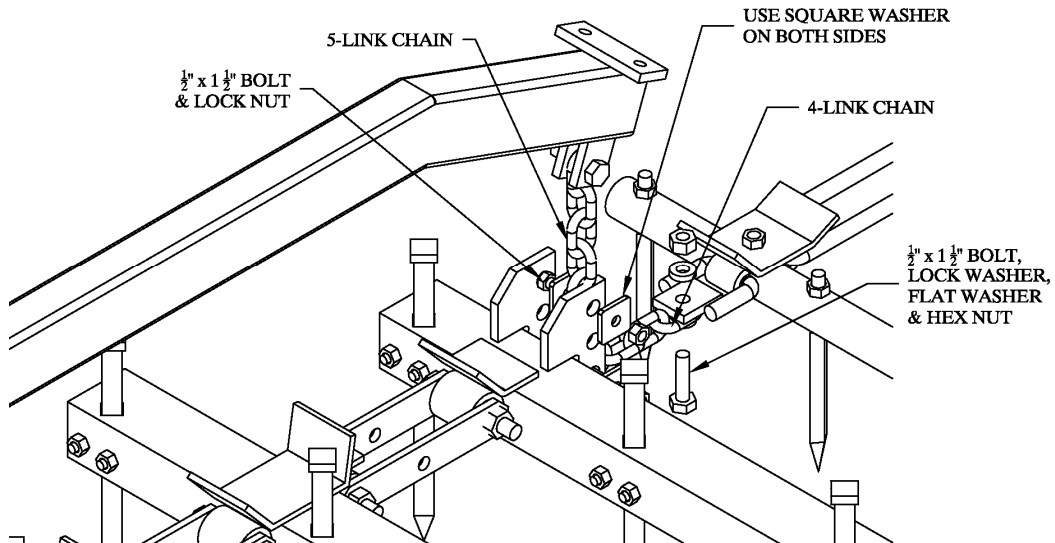

Figure 36

Decal Application and Final Adjustments

1. Your unit was provided with decals for properly marking the side, front and rear views. See Figures 37, 38 and 39. These Figures show decal descriptions and application locations for the left side of the unit. Repeat these instructions for the right side of the unit.
2. Check to make sure that all bolts and fasteners are tight.

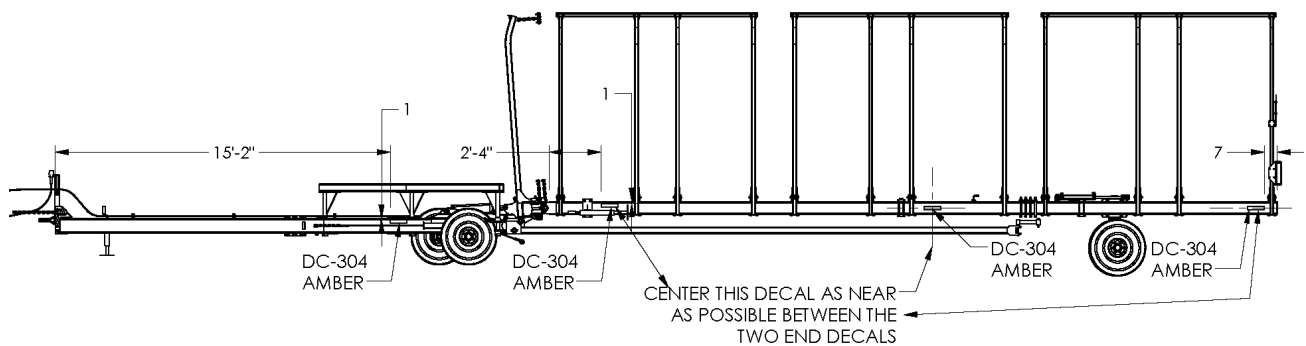

Figure 37

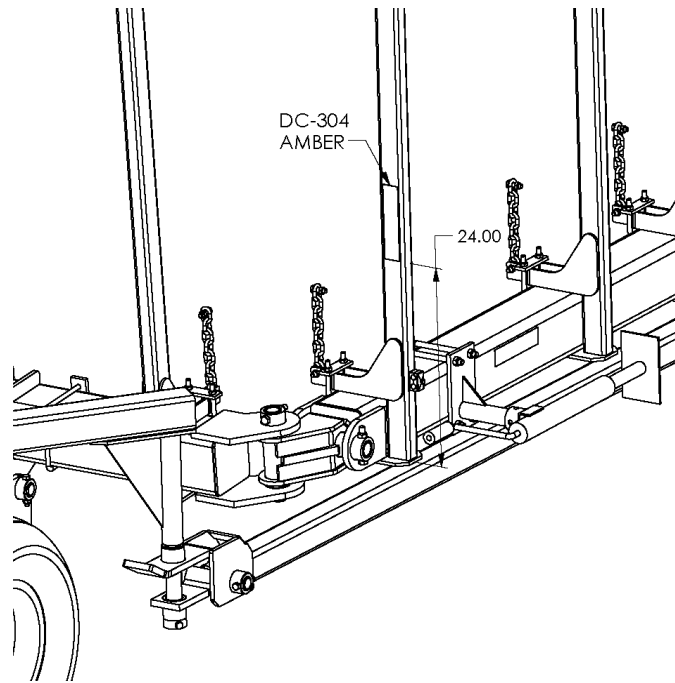

Figure 38

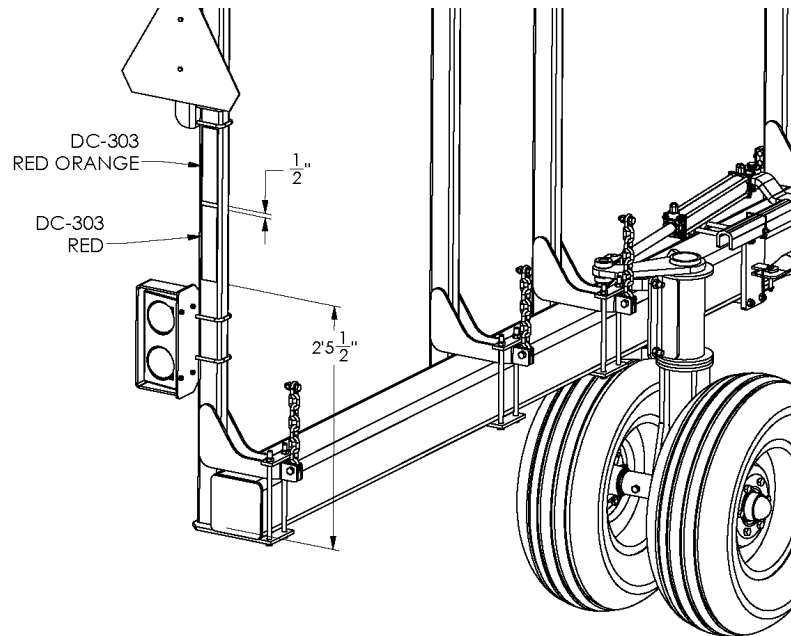

Figure 39

Do not detach the unit from the tractor unless the unit is in the transport position with jack stands down and the cylinder lock bars in place.

This completes the assembly of your harrow and transport cart. Before using the unit, double check that all components have been assembled properly. If there are any questions regarding any of the assembly steps, contact your local dealer for an explanation. Do not operate this or any equipment unless you are sure that all components operate as they were designed to operate.

TROUBLESHOOTING

PROBLEM	POSSIBLE CAUSE	SOLUTION
Hydraulics actuate too rapidly	Hydraulic restrictor not installed	Install hydraulic restrictor
Wing(s) not aligned with the center bar	Wing pull tube(s) improperly positioned	Reposition wing pull tube(s)
Excessive clogging during operations	Angle of attack too steep	Pull harrow sections from the other end
	Ground speed too low	Increase ground speed to 6 - 9 mph
Pivot arm will not lock securely	Pivot arm improperly positioned	Reposition pivot arm base
	Lock bracket assembly improperly positioned	Reposition pivot arm assembly
	Spring tension inadequate	Tighten spring on lock bracket assembly
Lock mechanism will not release when lift arms are raised completely	Cable/chain assembly is too long	Shorten chain at end of cable (CAUTION: do not overcompensate - damage to lock bracket assembly may occur if chain is too short)
Wing wheel tire wear	Wing wheel axle cylinder improperly adjusted	Adjust wing wheel cylinder yoke to ensure wheel track straight in the direction of travel.

BOLT TORQUE SPECIFICATIONS

Coarse Thread Series			Fine Thread Series		
Nut Size and Threads per Inch	Nut Tightening Torque (lb.ft.)		Nut Size and Threads per Inch	Nut Tightening Torque (lb.ft.)	
Grade C Nuts			Grade C Nuts		
	Max.	Min.		Max.	Min.
1/4 - 20	14.7	10	1/4 - 28	14.7	10
5/16 - 18	22.3	15.2	5/16 - 24	23.4	18.4
3/8 - 16	39	28	3/8 - 24	41	30
7/16 - 14	60	44	7/16 - 20	60	44
1/2 - 13	88	63	1/2 - 20	98	70
9/16 - 12	134	98	9/16 - 18	134	98
5/8 - 11	172	127	5/8 - 18	176	127
3/4 - 10	295	218	3/4 - 16	295	218
7/8 - 9	440	317	7/8 - 14	440	317
1 - 8	651	506	1 - 14	703	610

WHEEL LUG TORQUE SPECIFICATIONS

Tire Size	Lug Size	Lug Tightening Torque (lb.ft.)	
		Max.	Min.
18.5X8.5-8	½ nut	85	75
7.60-15	½ x 1	85	75
9.5L-15	½ x 1	90	80
11L-15	½ x 1	90	80
12.5L-15	9/16 x 1	90	80
13X13.5-15	9/16 x 1	90	80
425/65R 22.5	3/4 nut	90	80

WDL 2100 HARROW CART PARTS DIAGRAM

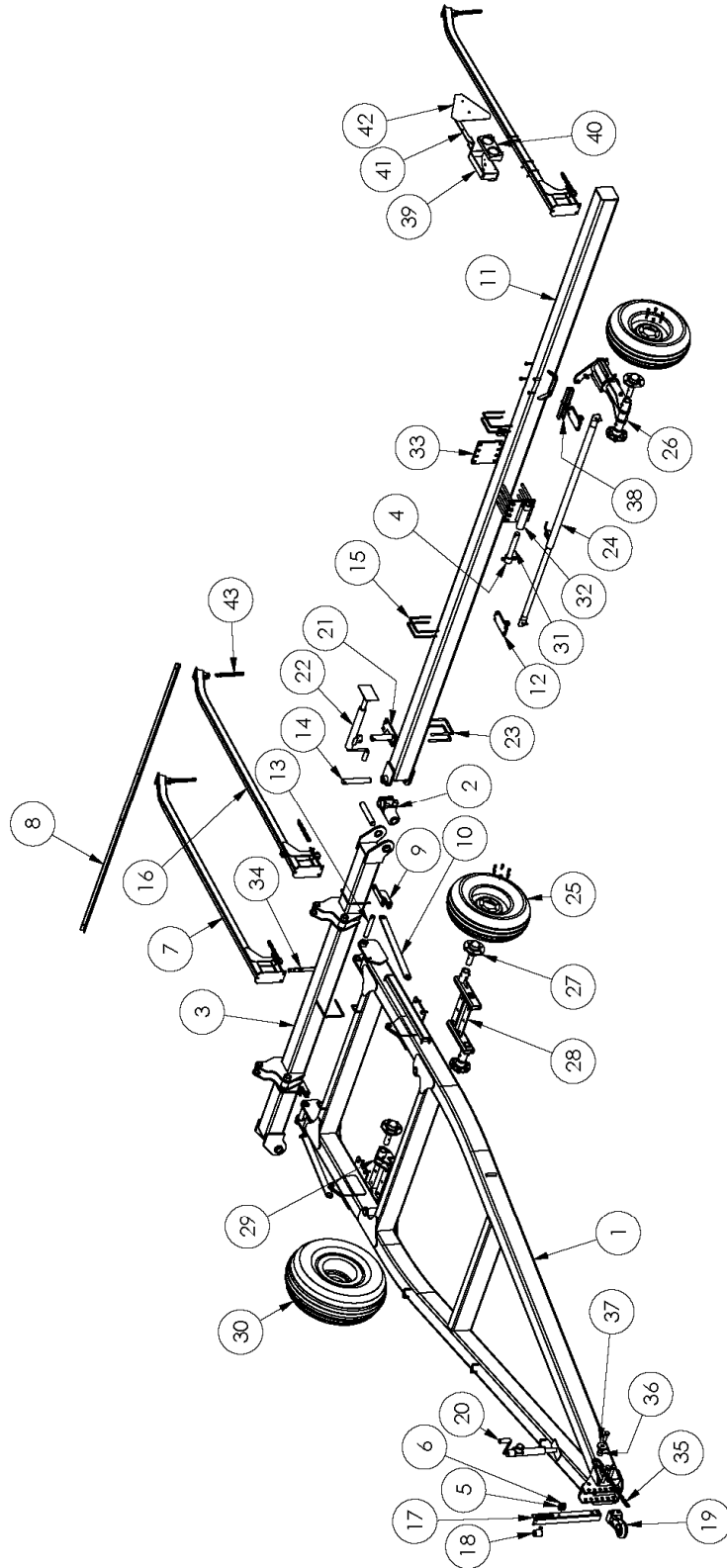

**WDL 2100 HARROW CART
PARTS LIST**

Always order by Part Number - *Not* by Key Number

KEY	PART #	DESCRIPTION	QTY.
1	12016	FRAME, MAIN	1
2	WDL-2733	HINGE KNUCKLE	2
3	12018	TOOLBAR, CENTER, 11'	1
4	WD-2936	SHORT BUSHING – 2"	4
5	HYO-1001	HYDRAULIC CLAMP SET	*
6	HYO-1004	HYDRAULIC CLAMP COVER	*
7	13042	LIFT ARM, 7" TOOLBAR, 110"	*
8	HD-3xxx	BRACE ANGLES	*
9	WD-2929	CB CABLE PULL, WITH EARS, 7"	2
10	SC-600	CYLINDER LOCKS	2
11	12964	WING TOOLBAR, LT 23' (WDL-2160)	1
**	12965	WING TOOLBAR, RT 23' (WDL-2160)	1
**	12960	WING TOOLBAR, LT 28' (WDL-2170)	1
**	12961	WING TOOLBAR, RT 28' (WDL-2170)	1
**	12021	WING TOOLBAR, LT 33' (WDL-2180)	1
**	12022	WING TOOLBAR, RT 33' (WDL-2180)	1
**	12501	WING TOOLBAR, LT 38' (WDL-2190)	1
**	12502	WING TOOLBAR, RT 38' (WDL-2190)	1
12	12103	TIEBAR BRACKET	3
13	RT-2107	PIN, STRAIGHT	2
14	WDL-2736	WDL WING HINGE PIN	4
15	BU-1278	U-BOLT, 1/2X 7 X 8.25	9
16	13043	LIFT ARM, 7" TOOLBAR, 110" W/CLIP	*
17	11948	HITCH STORAGE BRACKET	1
18	LB-1110	LIGHT PLUG STORAGE	1
19	PPI-400H	HITCH PINTLE, CAT IV	1
20	HD-1151	JACK, ROUND – 10", TOP, 2000#	1
21	WDL-2739	WING JACK PLATE, 7"	2
22	HD-1152	JACK, ROUND – 15", TOP, 2000#	2
23	BU-5879	U-BOLT, 5/8-11 X 7 X 8.5	4
24	12532	TIEBAR SET, LONG	1
*	WDL-3076	TIE BAR, OUTSIDE	*
*	12263	TIE BAR, INSIDE	*
25	12490	TIRE, IF280/70R15	*
*	HD-1368	RIM, 15X8, 6 BOLT, 2900 LB.	*
26	12097	WING AXLE ASSEMBLY, LT	1
**	12081	WING AXLE ASSEMBLY, RT	1

27	WDL-2507	HUB WITH SPINDLE (SEE FOLLOWING PAGE FOR PARTS DETAILS)	8
28	WDL-2506	WALKER AXLE (STANDARD 11L TIRE)	2
29	WDL-2503	DUAL AXLE, (14L TIRE OPTION)	2
30	11398	TIRE, 14L-16.1, 8 PLY	4
*	HD-1468	RIM, 16.1x11, 6-BOLT, 3500LB	*
31	12091	PIN, 1.75 X 13)	4
32	12075	BRACKET, WING ANCHOR	2
33	12077	CLAMP PLATE	2
34	WDL-2307	CENTER BAR HYDRAULIC TEE BRACKET	1
35	CH-1816	SAFETY CHAIN, 16,000 LBS	1
36	RT-2054	TUBE, ROUND, 1.88 O.D.X 1.31 I.D. - 1	1
37	RT-3103	SAFETY CHAIN WASHER	1
38	12958	CYLINDER LOCK, 2 X 14	2
39	12533	BRACKET, DUAL LIGHT	2
40	LB-1101	LIGHT, DUAL LEFT	1
**	LB-1101	LIGHT, DUAL RIGHT	1
41	12629	SMV MOUNT BRACKET, WDL	1
42	MM-1300	SMV SIGN	1
43	CH-0808	CHAIN, 3/8 – 8 LINK	*
**	DC-111	DECAL: "STAND CLEAR..."	1
**	DC-116	DECAL: "DO NOT CLIMB ON..."	1
**	DC-117	DECAL: "...USE JACK STAND"	1
**	DC-119	DECAL: "ESCAPING FLUID..."	1

-
- * Quantity depends on harrow sections used.
 - ** Unnumbered items are not pictured.
 - *** Please specify model number when ordering these parts.
 - xxx length in inches (84" is 084, 112" is 112)

McFarlane Manufacturing reserves the right to change specifications of design at any time without obligation to modify previous products.

WDL -2507 HUB AND SPINDLE ASSEMBLY

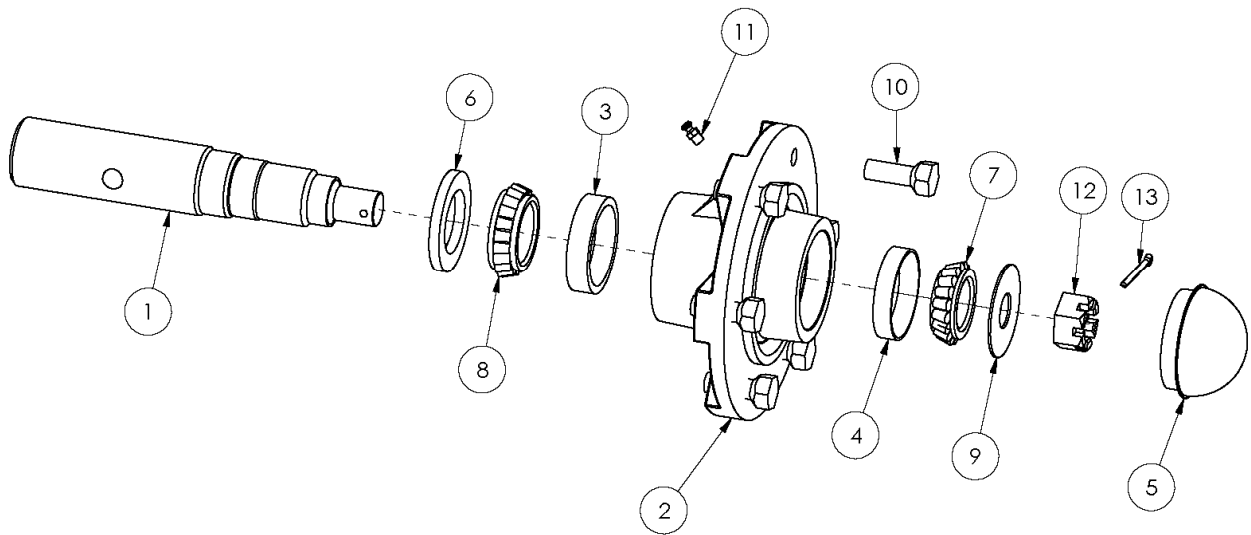

Always order by Part Number - *Not* by Key Number

KEY	PART #	DESCRIPTION	QTY.
1	WDL-2505	SPINDLE, 1 3/4 X 9 1/2	1
2	HD-1361	HUB, WITH RACES, 6 HOLE HUB	1
3	HD-1366	INNER RACE	1
4	HD-1171	OUTER RACE	1
5	HD-1367	DUST CAP	1
6	HD-1360	GREASE SEAL, 6 HOLE HUB	1
7	HD-1363	OUTER BEARING	1
8	HD-1362	INNER BEARING	1
9	HD-1364	SPINDLE FLAT WASHER	1
10	WB-5010	WHEEL BOLTS	6
11	GZ-0601	GREASE FITTING	1

FH-8-BAR HARROW SECTIONS PARTS DIAGRAM & LISTING

INCLUDES FH-500-8, FH-600-8, FH-700-8, FH-800-8, AND FH-900-8

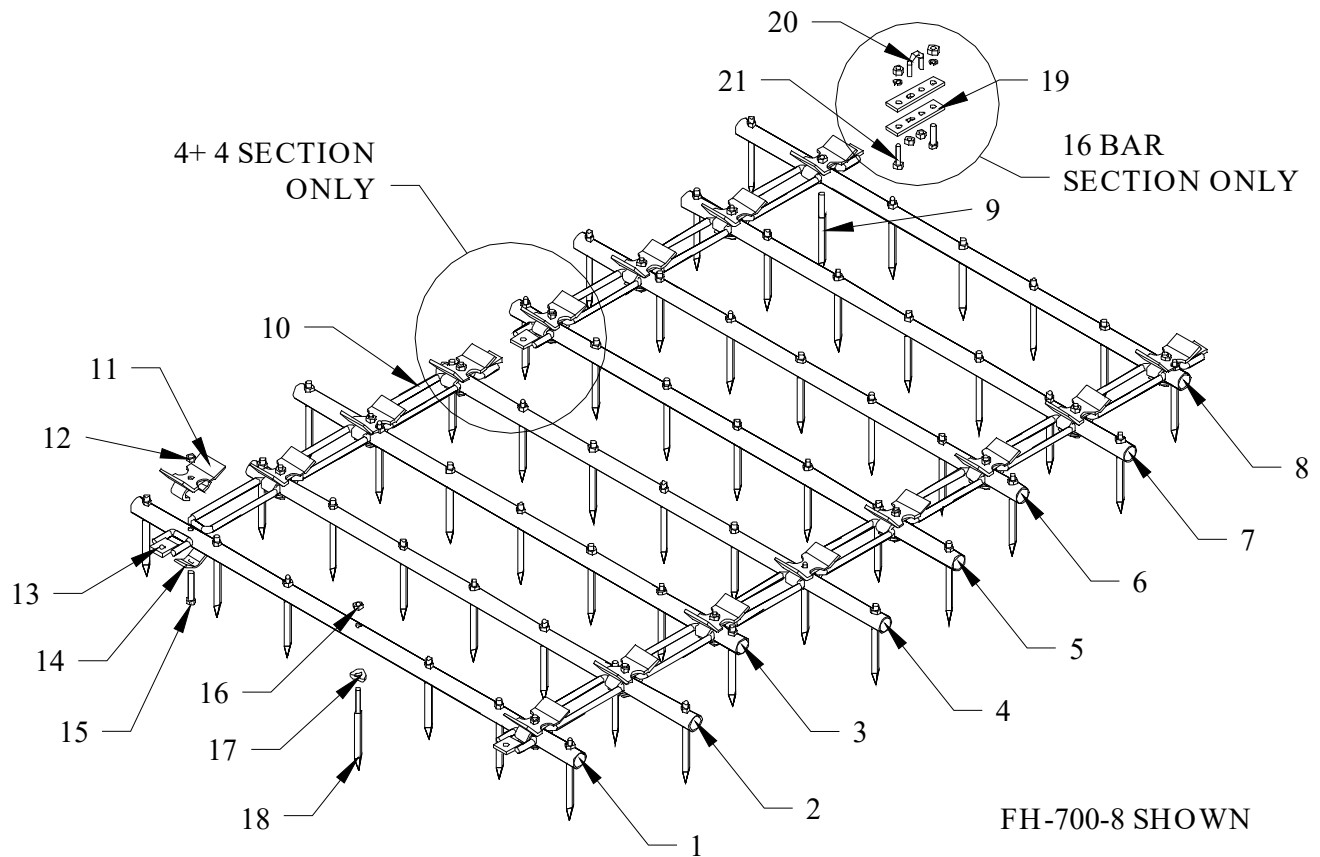

ITEM #	PART #	DESCRIPTION
1	FH-801	#1 HARROW BAR (FH-500-8)
1	FH-805	#1 HARROW BAR (FH-600-8)
1	FH-809	#1 HARROW BAR (FH-700-8)
1	FH-813	#1 HARROW BAR (FH-800-8)
1	FH-817	#1 HARROW BAR (FH-900-8)
2	FH-802	#2 HARROW BAR (FH-500-8)
2	FH-806	#2 HARROW BAR (FH-600-8)
2	FH-810	#2 HARROW BAR (FH-700-8)
2	FH-814	#2 HARROW BAR (FH-800-8)
2	FH-818	#2 HARROW BAR (FH-900-8)
3	FH-802	#3 HARROW BAR (FH-500-8)
3	FH-806	#3 HARROW BAR (FH-600-8)
3	FH-810	#3 HARROW BAR (FH-700-8)
3	FH-814	#3 HARROW BAR (FH-800-8)
3	FH-818	#3 HARROW BAR (FH-900-8)
4	FH-804	#4 HARROW BAR (FH-500-8)
4	FH-808	#4 HARROW BAR (FH-600-8)
4	FH-812	#4 HARROW BAR (FH-700-8)

4	FH-816	#4 HARROW BAR (FH-800-8)
4	FH-820	#4 HARROW BAR (FH-900-8)
5	FH-803	#5 HARROW BAR (FH-500-8)
5	FH-807	#5 HARROW BAR (FH-600-8)
5	FH-811	#5 HARROW BAR (FH-700-8)
5	FH-815	#5 HARROW BAR (FH-800-8)
5	FH-819	#5 HARROW BAR (FH-900-8)
6	FH-803	#6 HARROW BAR (FH-500-8)
6	FH-807	#6 HARROW BAR (FH-600-8)
6	FH-811	#6 HARROW BAR (FH-700-8)
6	FH-815	#6 HARROW BAR (FH-800-8)
6	FH-819	#6 HARROW BAR (FH-900-8)
7	FH-801	#7 HARROW BAR (FH-500-8)
7	FH-805	#7 HARROW BAR (FH-600-8)
7	FH-809	#7 HARROW BAR (FH-700-8)
7	FH-813	#7 HARROW BAR (FH-800-8)
7	FH-817	#7 HARROW BAR (FH-900-8)
8	FH-804	#8 HARROW BAR (FH-500-8)
8	FH-808	#8 HARROW BAR (FH-600-8)
8	FH-812	#8 HARROW BAR (FH-700-8)
8	FH-816	#8 HARROW BAR (FH-800-8)
8	FH-820	#8 HARROW BAR (FH-900-8)
9	E-611	1/2" x 3" SHANK SPIKE TOOTH ONLY
10	FH-125	CONNECTOR LINK (REGULAR)
11	FH-127	NOTCHED LINK CAP
12	**	1/2" LOCK NUT
13	FH-122	PULL FLAT
14	FH-019	CAP CLIP
15	**	1/2" x 3" BOLT
16	**	1/2" FLANGED LOCK NUT
17	E-630	SPIKE TOOTH WASHER
18	E-620	1/2" x 2 1/2" SHANK SPIKE TOOTH ONLY
**	E-610	1/2" x 2 1/2" SHANK SPIKE TOOTH w/WASHER
19	HDL-5100	DUAL SECTION CONNECTOR FLAT (16 BAR ONLY)
20	BV-7611	7/16" V-BOLT (16 BAR ONLY)
21	**	1/2" x 2" BOLT, LOCK WASHER AND NUT (16 BAR ONLY)
**	HDL-5101	DUAL SECTION CONNECTOR ASSEMBLY (16 BAR ONLY)

The #1 bar is the bar with an equal amount of tube to the right and left of the pull flats. The #8 bar is the bar that is staggered off to one side.

When pulling the harrow section from the #1 bar, the teeth will be in the least aggressive setting. When pulling from the #8 bar the teeth will be in the most aggressive setting.

9/24/08

FA-710-8-BAR HARROW SECTION

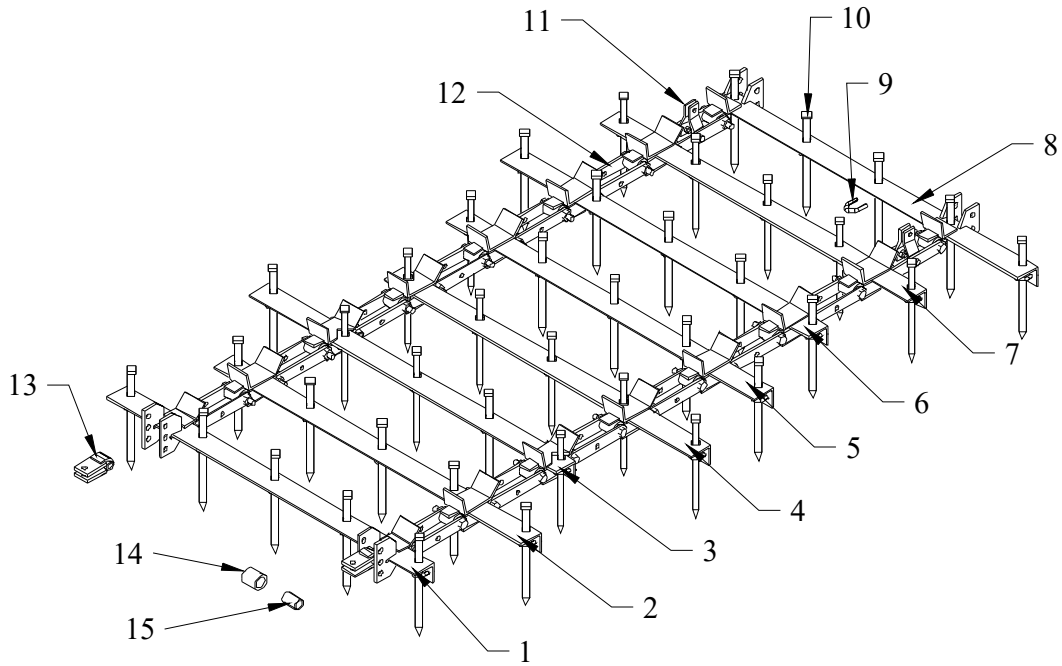

ITEM #	PART #	DESCRIPTION
1	FA-791	#1 HARROW BAR
2	FA-792	#2 HARROW BAR
3	FA-793	#3 HARROW BAR
4	FA-794	#4 HARROW BAR
5	FA-795	#5 HARROW BAR
6	FA-796	#6 HARROW BAR
7	FA-797	#7 HARROW BAR
8	FA-798	#8 HARROW BAR
9	BV-3812	3/8 V-BOLT
10	FA-4110	3/4" X 10" TOOTH
11	CT-104	CHAIN CLIP
12	FA-4035	CONNECTOR FLAT, 8-BAR
13	FA-4105	PULL HOOK
14	CT-107	OUTER BUSHINGS
15	CT-102	INNER BUSHINGS

12/11

**WDL-2100 HARROW CART
MAIN FRAME
HYDRAULICS PARTS LIST**

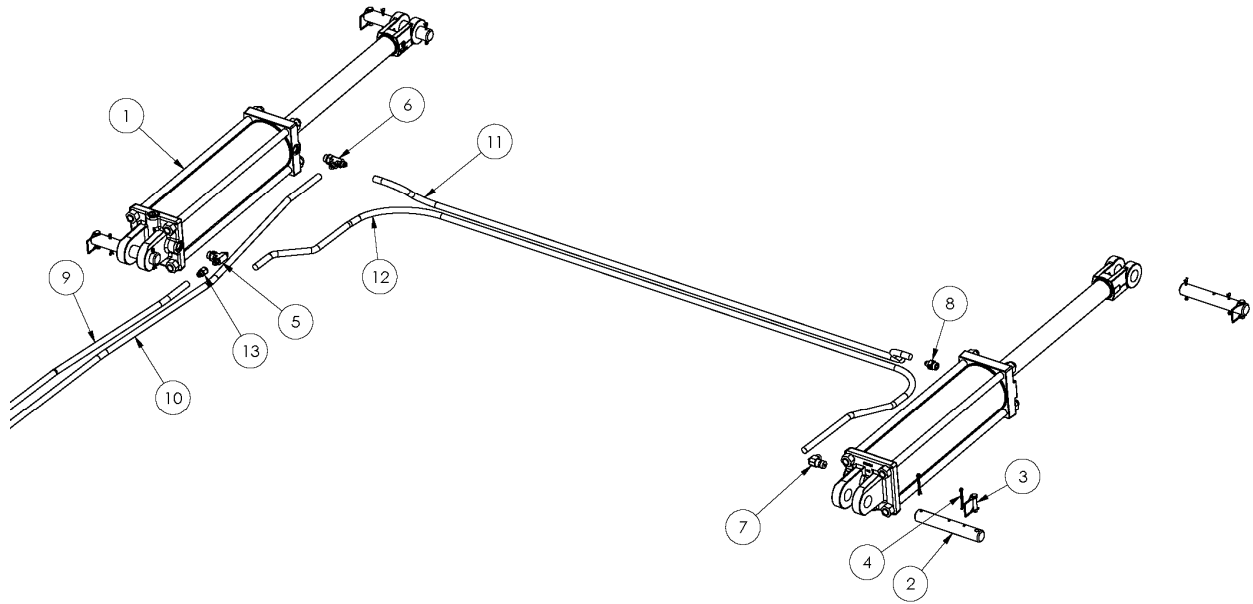

KEY	PART #	DESCRIPTION	QTY.
1	HYA-35016	ASAE 4" x 16" HYDRAULIC CYLINDER (2040 – 2060)	2
2	12023	PIN, CYLINDER, LOCK	4
3	LP-3815	PIN, LYNCH, 3/8 x 1 1/2	4
4	CP-3620	PIN, COTTER, 3/16 X 2	8
5	HYF-1808	HYD TEE, 9/16M-3/4Morb-9/16M	1
6	HYF-1088	HYD TEE, 3/8M-3/8M-1/2Morb	1
7	HYF-2820	HYD ELBOW, 3/8M - 1/2Morb	1
8	HYF-3820	HYD ADAPTER, 3/8-M-3/4Morb	1
9	12550	HYD HOSE,3/8(9/16F-1/2PIPE), DISC,280	1
10	12551	HYD HOSE,3/8(9/16F-1/2PIPE), DISC,300	1
11	14088	HYD HOSE,3/8(9/16F),78	1
12	HYH-8110	HYD HOSE,3/8(9/16F),110	1
13	11391	HYD RESTRICTOR, 9/16F-9/16M,1/16	1

Note: When ordering cylinder replacement parts, please specify cylinder make & part number.

McFarlane Manufacturing reserves the right to change specifications of design at any time without obligation to modify previous products.

HYDRAULIC TRANSPORT WHEEL PARTS DIAGRAM

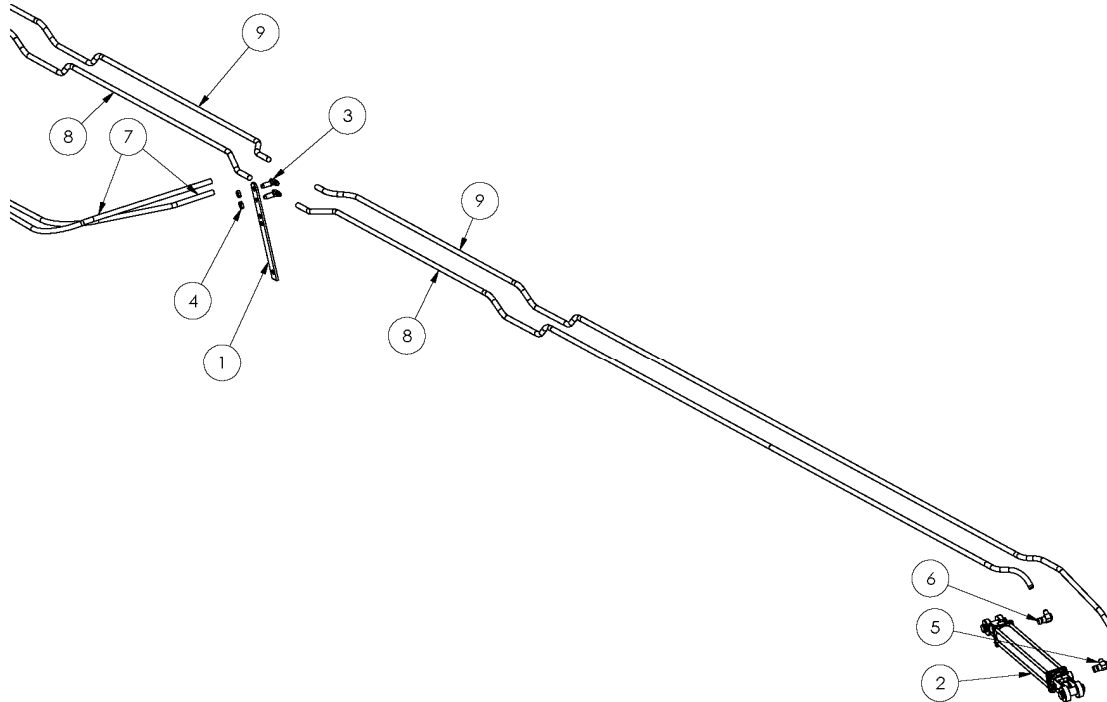

TRANSPORT WHEEL HYDRAULICS PARTS LIST

Always order by Part Number - *Not* by Key Number

KEY	PART #	DESCRIPTION	1
1	WDL-2307	CENTER BAR HYDRAULIC TEE BRACKET	2
2	HYC-32014	2" x 14" HYDRAULIC CYLINDER (TIE-ROD STYLE)	2
3	HYF-1888	TEE (9/16M-3/4Morb-9/16M)	2
4	HYO-4000	3/8" HYDRAULIC TEE NUT	2
5	HYF-2821	HYD ELBOW, 9/16M-3/4Morb, RST	2
6	HYF-2820	HYD ELBOW, 9/16M – 3/4Morb	2
7	12554	HYDRAULIC HOSE 3/8 (9/16F – 1/2 PIPE)	2
8	13949	HYDRAULIC HOSE, 3/8 (9/16F), 268" (2160)	2
8	13948	HYDRAULIC HOSE, 3/8 (9/16F), 320" (2170)	2
8	12970	HYDRAULIC HOSE, 3/8 (9/16F), 383" (2180)	2
8	12552	HYDRAULIC HOSE, 3/8 (9/16F), 455" (2190)	2
9	HYH-8285	HYDRAULIC HOSE, 3/8 (9/16F), 285" (2160)	2
9	13001	HYDRAULIC HOSE, 3/8 (9/16F), 336" (2170)	2
9	HYH-8400	HYDRAULIC HOSE, 3/8 (9/16F), 400" (2180)	2
9	12553	HYDRAULIC HOSE, 3/8 (9/16F), 472" (2190)	2

** Unnumbered items are not pictured.

*** Please specify model number when ordering these parts.

Bolts, washers, and nuts are not shown. Refer to the step-by-step assembly instructions for details.

McFarlane Manufacturing reserves the right to change specifications of design at any time without obligation to modify previous products.

AUTO-BACKUP WING PULL-TUBE PARTS DIAGRAM

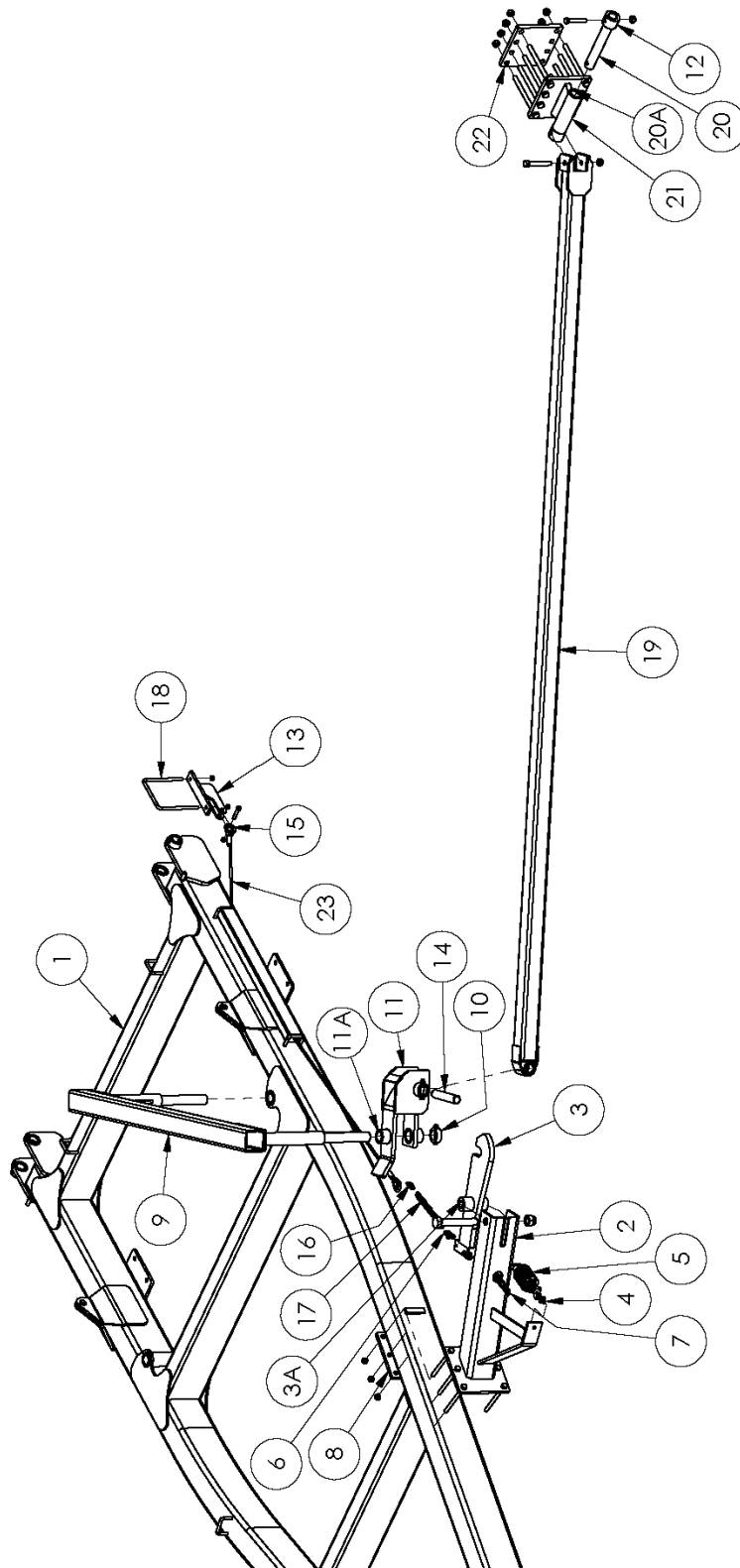

**AUTO-BACKUP WING PULL-TUBE
PARTS LIST**

Always order by Part Number - *Not* by Key Number

KEY	PART #	DESCRIPTION	QTY.
1	12016	MAIN FRAME	1
2	12017	LEFT LOCK BRACKET ASSEMBLY	1
**	12017	RIGHT LOCK BRACKET ASSEMBLY	1
3	12102	LOCK ARM	2
3A	10691	BUSHING, PLASTIC	4
4	EB-1202	EYE BOLT, 1/2-13 X 2	2
5	11014	EXTENSION SPRING	2
6	AL-030	ANCHOR SHACKLE, 5/16	4
7	CH-0703	CHAIN, 7 $\frac{3}{8}$ -3 LINK	2
8	WD-2912	CLAMP PLATE	2
9	12020	BRACKET, PIVOT ARM	2
10	WD-2911	TUBE, ROUND, ANTI-ROTATION	4
11	12019	BRACKET, CONNECTOR	2
11A	12071	BUSHING, PLASTIC	4
12	WD-2936	SHORT BUSHING, 2"	4
13	WD-2929	CB CABLE PULL W / EARS	2
14	SPR-2712	PIN, STRAIGHT	2
15	HD-1216	HITCH CAP BUSHING	2
16	WD-181	QUICK LINK, 1/4	2
17	CH-0609	CHAIN, 5/16, 9 LINK	2
18	BU-1278	U-BOLT, 1/2-13 X 7 X 8 1/4	2
19	12973	PULL TUBE, 14' (WDL-2160)	2
**	12962	PULL TUBE, 18' (WDL-2170)	2
**	12073	PULL TUBE, 23' (WDL-2180 – 2190)	2
20	12091	PIN, 1.75 X 13	2
20A	12071	BUSHING, PLASTIC	4
21	12075	BRACKET, WING ANCHOR	2
22	12077	CLAMP PLATE	2
23	WC-8105	CABLE	2

** Unnumbered items are not pictured.

*** Please specify model number when ordering these parts.

McFarlane Manufacturing reserves the right to change specifications of design at any time without obligation to modify previous products.

LIGHT KIT PARTS LIST

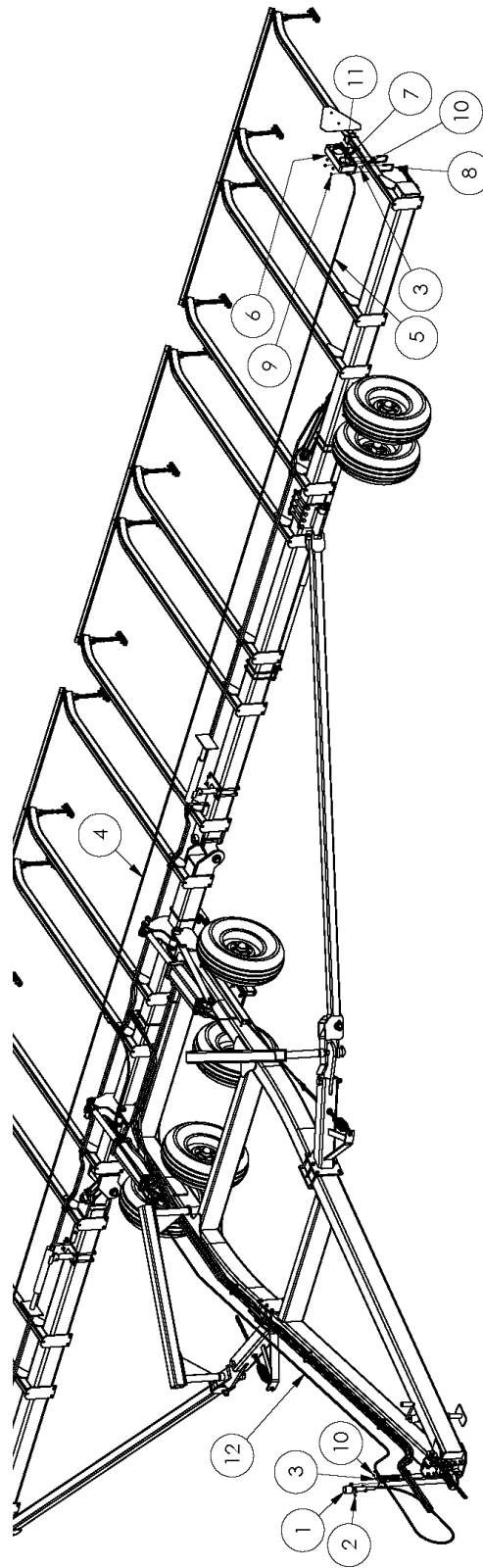

LIGHT KIT PARTS LIST

KEY	PART #	DESCRIPTION	
1	LB-1110	LIGHT PLUG STORAGE	2
2	BH-2510	HEX BOLT, 1/4X 1	2
3	LW-0025	LOCK WASHER, 1/4"	10
4	LB-1450	LIGHT HARNESS, WISHBONE (50')	1
5	LB-1510	LIGHT HARNESS WISHBONE EXTENSION	2
5	LB-1510	LIGHT HARNESS WISHBONE EXTENSION (WDL-2190)	4
**	LB-1505	LIGHT HARNESS WISHBONE EXTENSION (WDL-2180)	2
6	12533	BRACKET, DUAL LIGHT	2
7	LB-1101	LIGHT, DUAL, LEFT	1
**	LB-1102	LIGHT, DUAL, LEFT	1
8	BU-3824	U-BOLT, 3/8-16 X 2 X 3.75	4
9	NLT-3816	LOCKING HEX NUT, 3/8	8
10	NH-2520	HEX NUT, 1/4	8
11	BH-2513	HEX BOLT, 1/4-20 X 1.25, GRADE 5	8
12	LB-1330	LIGHT HARNESS, STRAIGHT, 30'	1

** Unnumbered items are not pictured.

McFarlane Manufacturing reserves the right to change specifications of design at any time without obligation to modify previous products.

WDL-2160 HARROW CART LAYOUT DIAGRAM

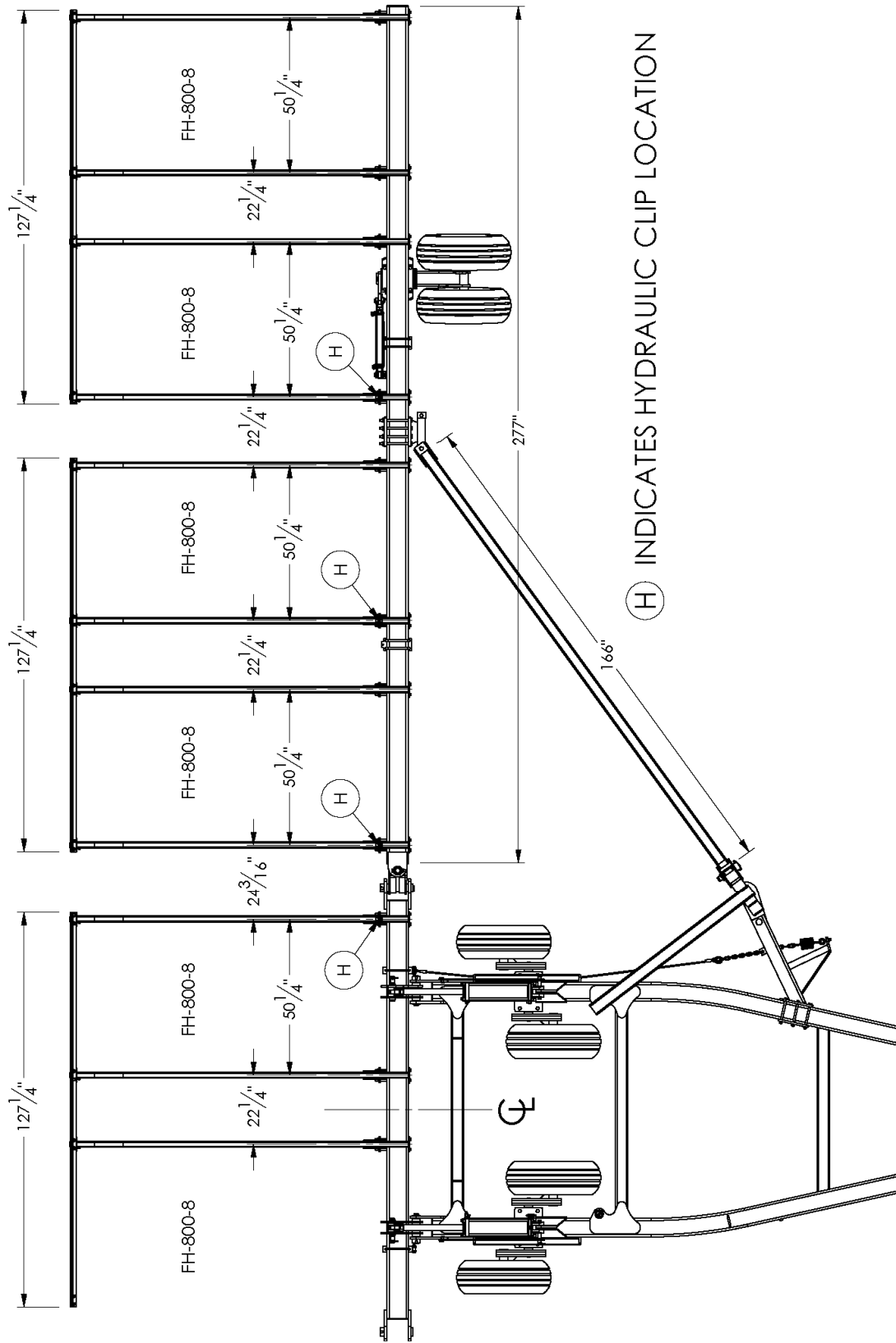

Ⓜ INDICATES HYDRAULIC CLIP LOCATION

WDL-2180 HARROW CART LAYOUT DIAGRAM

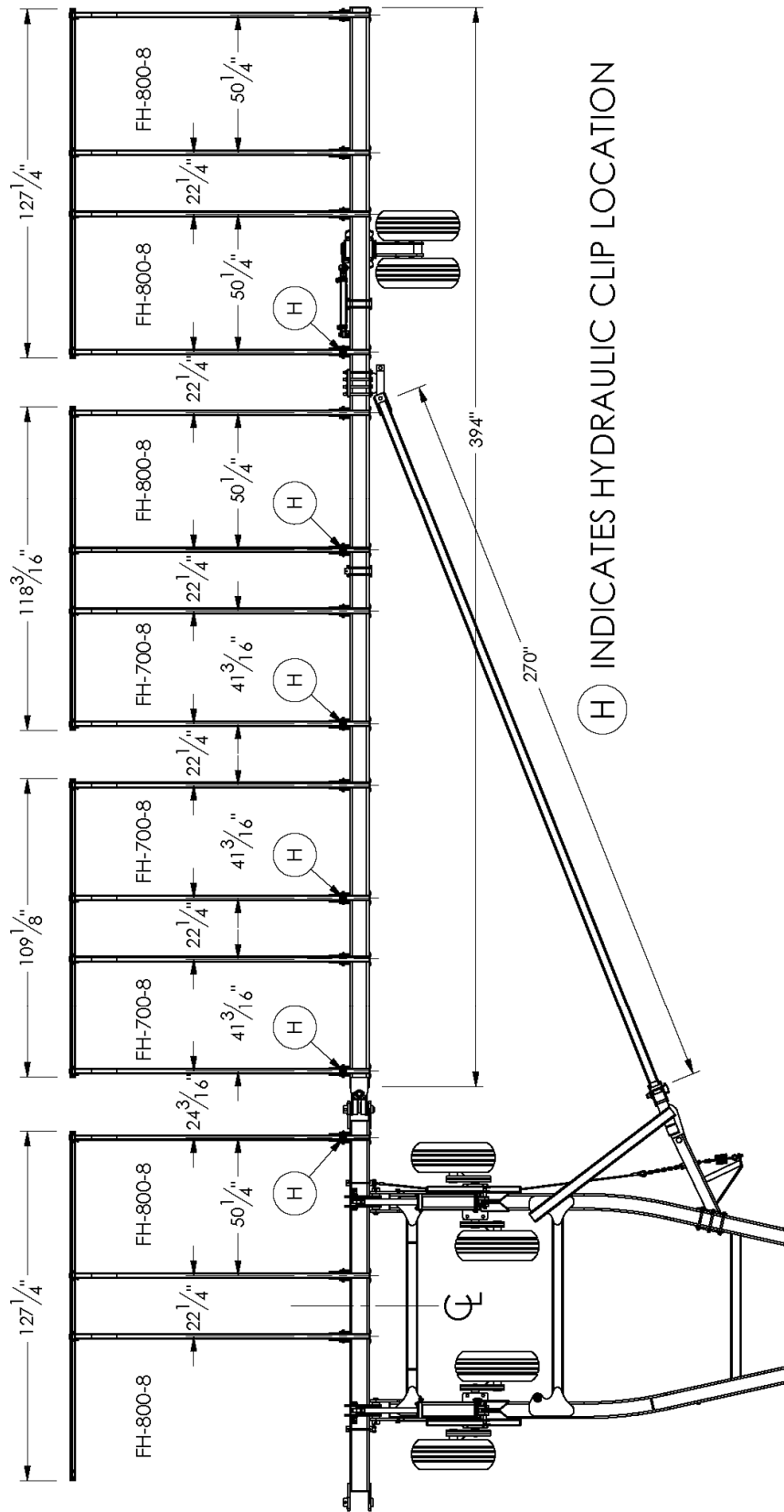

(H) INDICATES HYDRAULIC CLIP LOCATION

WDL-2190 HARROW CART LAYOUT DIAGRAM

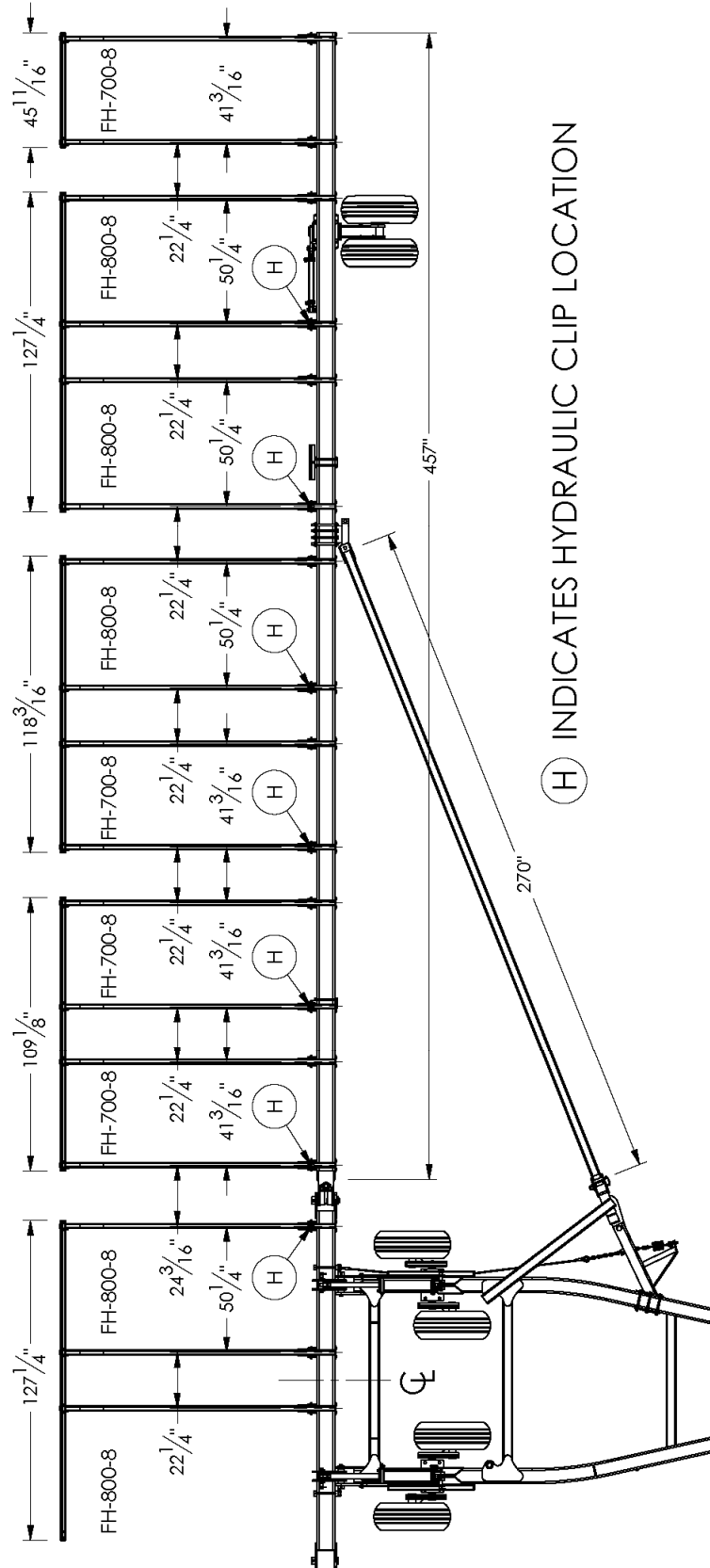

WARRANTY REGISTRATION FORM

This form must be filled out by the dealer and owner and sent to: McFarlane Mfg. Co., Inc.,
1330 Dallas Street, P.O. Box 100, Sauk City, WI 53583.

WARRANTY REGISTRATION FORM & INSPECTION REPORT

WARRANTY REGISTRATION

This form must be filled out by the dealer and signed by both the dealer and customer at the time of delivery.

Customer Name _____ Dealer Name _____

Address _____ Address _____

City, state, code _____ City, state, code _____

Phone number (____) _____

Model _____ Serial Number _____ Delivery Date _____

DEALER INSPECTION REPORT

_____ Wheel bolts tight
_____ Fasteners tight
_____ Hydraulic hoses free
_____ Hydraulic fittings tight
_____ Arms free
_____ Check tire pressures
_____ Lubricate machine

SAFETY

_____ All decals installed
_____ Review operating and safety instructions

I have thoroughly instructed the buyer on the above described equipment; review included the operator's manual content, equipment care, adjustments, safe operation and applicable warranty policy.

Date _____ Dealer's signature _____

The above equipment and operator's manual have been received by me and I have been thoroughly instructed as to care, adjustments, safe operation, and applicable warranty policy.

Date _____ Owner's signature _____

Dealer Contact Information

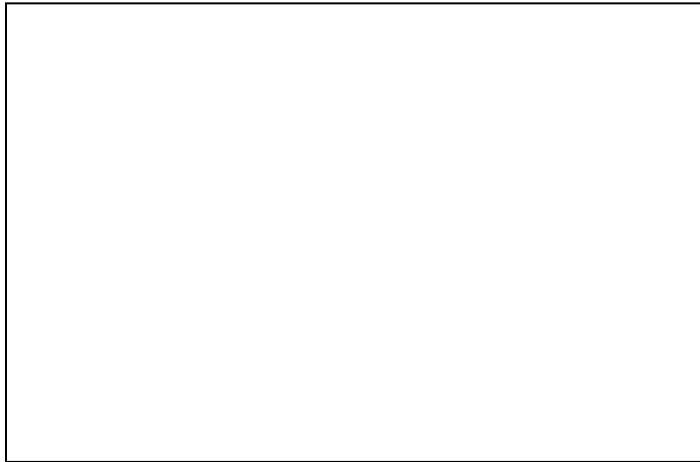

McFARLANE MANUFACTURING CO. INC.
1330 DALLAS STREET, P.O. BOX 100
SAUK CITY, WISCONSIN 53583
PHONE: (608) 643-3321
TOLL FREE: (800) 627-8569
FAX: (608) 643-3976
WEB: www.mcfarlaneag.com